

September 2015



Commercial
Vehicles

The new

Transporter





The new Transporter panel van.

Introducing the new Transporter. A vehicle like no other.

When we designed our first compact van some 65 years ago, Volkswagen Commercial Vehicles succeeded in capturing both the imagination and needs of professionals. Since then, each new generation of Transporter has added to the legacy.

And now, with the launch of our latest 6th generation Transporter, we've exceeded expectations again and created a van that's designed to lead the way. Its interior is packed full of innovations and modern-day technology to assist your working day. Its stylish exterior is contemporary and designed to make a statement. It's this constant evolution that sets the new Transporter apart as a technical trailblazer.

Space for up to **3** Euro-pallets.

Up to **9.3m³** load compartment volume.

Up to **1,331kg** payload.

Up to **1,940mm** loading height.

Up to **2,500kg** trailer weight.

Up to **2,975mm** load compartment length.

02 Introducing the new Transporter.

- 04 Working with you.
- 06 Design.
- 08 Interior.
- 10 Safety systems.
- 12 Assistance systems.
- 14 Engines and gearboxes.
- 16 BlueMotion Technology.
- 18 4MOTION.
- 20 Rear door solutions.
- 22 Load space solutions.

24 Choose your van.

- 28 Transporter panel van.
- 30 Transporter kombi.

32 Choose your trimline.

- 32 Startline.
- 34 Trendline.
- 35 Highline.

36 Paint and upholstery.

- 38 Alloy wheels.
- 38 Audio and communications.
- 40 Mobile online services.

41 Engine and gearbox data.

- 42 Economy and performance.
- 44 Dimensions.
- 46 Weights.

48 Service and warranties.



The new Transporter kombi.

Volkswagen Commercial Vehicles
Van Centres.

Working with you.

It's more than a van to you. You're more than a customer to us.

We know that when you choose Volkswagen Commercial Vehicles, you're looking for more than just four walls on four wheels. You want a van that looks after itself while you take care of business. A vehicle that makes a statement, as well as a delivery. An investment for the future that makes a difference today.

To us, you're a partner.

By getting to know how you work and what you need, we can give you more. That means helping your business become stronger and leaner, supporting your plans year after year. It means a partnership that lasts as long as your ownership, with a vehicle and a team that's with you for the journey.

Our dedicated network of Van Centres.

Over 70 Van Centres and 24 Authorised Repairers means you're only around 45 minutes from our door, wherever your work takes you.

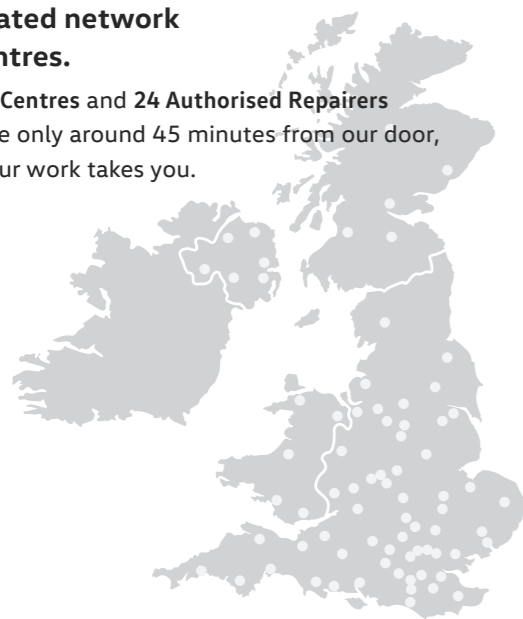

All you'll ever need.

Everything for the job... ...and the journey.

The right van.

We're commercial vehicle experts and finding the right van for your business is what makes us tick. We'll guide you through the range, take you on a test drive and cover all the options.

The right accessories.

From mudflaps to sat navs, plying to roof racks, we'll work with you to create the perfect van – keeping everything 100% Volkswagen to preserve its class-leading residuals.

The right finance.

Every business is different, so we stay flexible, with a range of finance packages to choose from. Depending on your preference, we'll go through the options to find the one that suits you best.

The right support.

Nothing matters more than keeping you mobile, so our servicing options are built around you. You'll also enjoy three-years free Roadside Assistance with your new van.

The right service.

We understand it's the little things that make the difference, so we set high standards. We'll call you when we say, keep you informed on delivery dates and support you long after purchase.

And there's more...

We offer a lot more than you might think. From **cost-effective van rental** to a wide selection of premium and budget **replacement tyres**, or an **air conditioning recharge** to pointing you to a **local sign-writer**, we're able to help!

For more information on service, support and warranties, take a look at **page 48**.

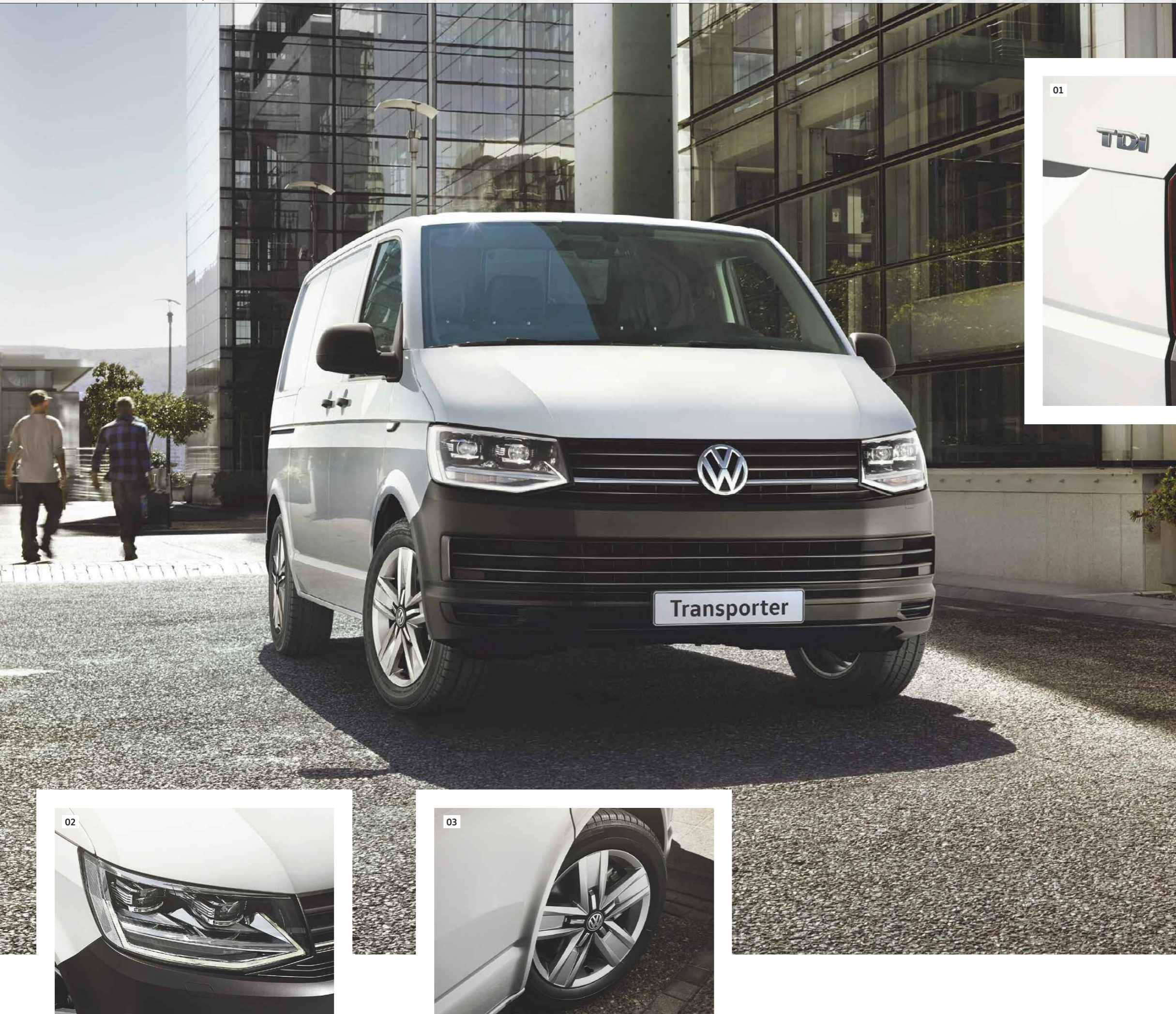

Professional from every angle.
The new design.

The new Transporter succeeds in catching the eye. Precise styling and defined contours give the new design a striking look and make a statement. While the front delivers a bold new stance with attractive headlights and a purposeful bumper, the rear features elegantly sculptured rear light clusters. Additional highlights include a new chrome strip on the radiator grille, stylish side indicators and a new range of alloy wheels.

- 01 Optional low energy LED rear light clusters.
 02 Optional low energy LED headlights.
 03 17" Devonport alloy wheels – from our new range of stylish alloy wheels.

Delivering style, comfort and quality.

The new interior.

Designed to impress, the new Transporter is packed with features that benefit comfort, convenience and offer assistance while you work. Step inside and you'll find a stylish new dashboard with plenty of storage solutions and a quality finish. Everything within the cab has been carefully thought through – from ergonomic seating, to controls and functions that are arranged to be within easy reach.

Combining the use of robust materials and high-quality production methods, just like its predecessors, the new Transporter's interior will stand the test of time. Add to this a broad selection of radio and infotainment systems featuring up-to-the-minute technology – including DAB radio and Bluetooth® as standard, not to mention the latest advances in safety, and you'll discover the new Transporter is a safe, comfortable and enjoyable place to spend your working day.

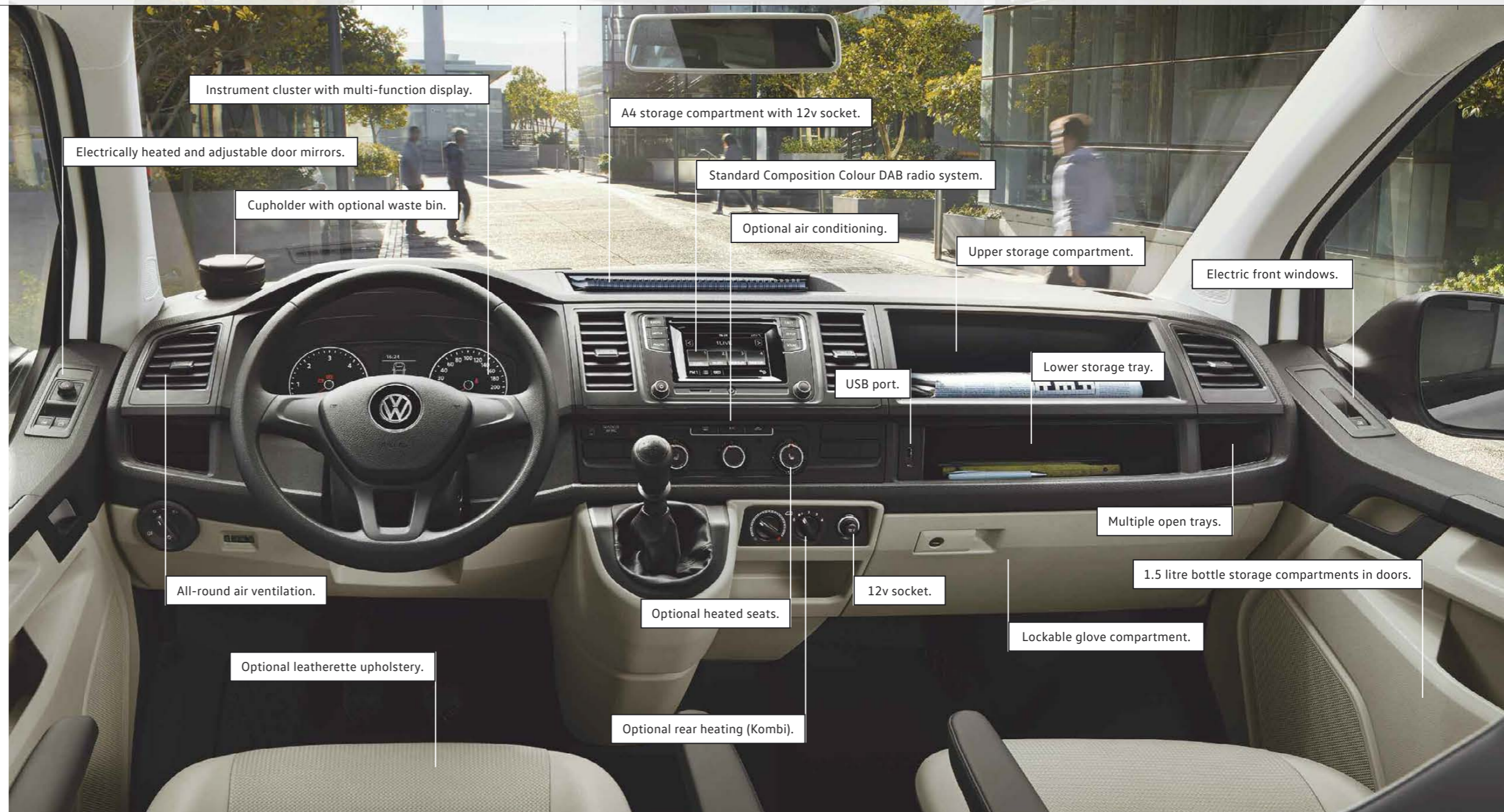

01 The panel van's two-seat front passenger bench with optional integral storage.

02 Optional App-Connect system.



The new radio and infotainment systems.

Radio and navigation.

Latest-generation devices are available, including the Composition Colour and Composition Media DAB radio systems, as well as the Discover Media navigation system.

Voice recognition.

The voice control system allows you to operate the telephone, navigation and audio functions without taking your hands off the steering wheel.

App-Connect.

You can easily and safely operate special apps using this interface. It allows you to view and operate content and functions from your smartphone on the infotainment touchscreen.

Connectivity package.

External media devices, such as MP3 players, can be connected via the USB port. Additionally, the mobile phone interface offers a Bluetooth® hands-free speaking system.



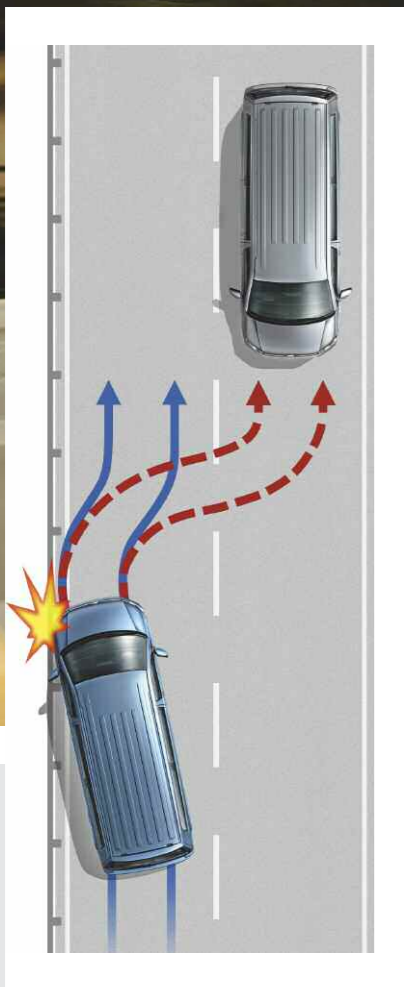

Automatic Post-Collision Braking System.
Standard on all Transporter models, it triggers braking after a collision, with the aim of preventing secondary collisions.



Electronic Stabilisation Programme (ESP).
Prevents the vehicle from swerving in critical driving conditions by controlled and targeted intervention in the brake and engine management. Thus, the vehicle achieves maximum directional stability.



Anti-lock Braking System (ABS).
Prevents wheels from locking up and therefore significantly improves the manoeuvrability of the vehicle under heavy braking.



Traction Control System (TCS).
Aids smooth starts and acceleration by reducing wheel-spin. The system also incorporates the Electronic Differential Lock (EDL) and makes up part of the Electronic Stabilisation Programme (ESP).



Electronic Differential Lock (EDL).
Allows smooth starts on slippery or loose road surfaces. If one wheel starts to spin, EDL will brake the wheel as necessary, directing power to the wheel with greater traction.



Airbags.
Driver and passenger front airbags are standard for the first time. They offer occupants the best possible protection in the event of head-on or side impacts.



Seatbelt warning.
The seatbelt warning reminds the driver that their seatbelt is not fastened. An audiovisual signal is used to request that the seatbelt is fastened before driving.

Your safety is our priority. Safety systems.

Your safety is a vital factor, so we ensure that a long list of safety and security features are built into every vehicle we produce. Since we first introduced structural safety features on commercial vehicles over 35 years ago, Volkswagen's policy of continuous safety development has been setting the pace. Every Volkswagen model incorporates a range of both active and passive safety features, to ensure the safety and security of both you and your load.

Almost every part of the vehicle's design contributes to safety. Occupants are securely enclosed within a rigid safety cell with crumple zones to absorb crash energy, while the chassis and suspension are designed for excellent directional stability and handling. Features such as Anti-lock Braking System (ABS), Electronic Brakeforce Distribution (EBD/EBV), Electronic Stabilisation Programme (ESP), driver and passenger front airbags, electric seatbelt tensioners and Automatic Post-Collision Braking System are fitted as standard.

For extra security and protection, an electronic immobiliser and remote central locking with dead locking and internal locking button are standard, while optional features such as anti-theft devices, front and rear parking sensors, Bi-xenon headlights, automatic rain-sensing wipers and front fog lights with integrated cornering lights all offer additional peace-of-mind.



Adaptive Cruise Control (ACC).
Available as an option, ACC uses a front radar to measure the distance (up to 120m) and speed relative to vehicles driving ahead. It automatically regulates the pre-set distance. ACC also includes the **Front Assist area monitoring system with City Emergency Braking System**. This detects critical distances, warns of hazardous situations and when necessary, triggers emergency braking.



Lane Change Assist – Side Scan.
Available as an option, Side Scan displays a warning signal on the exterior mirror as soon as one of its sensors detects a vehicle in a blind spot during a lane change.

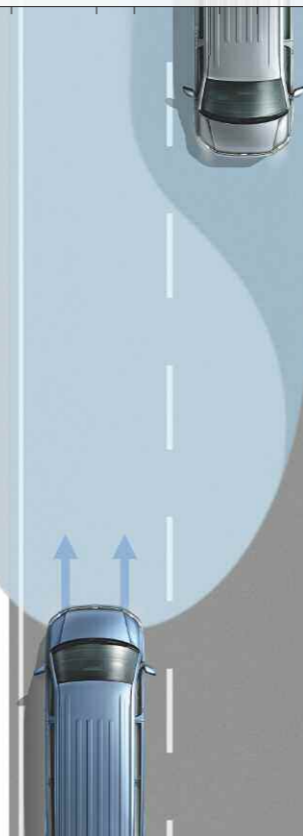

High Beam Assist.
Available as an option, High Beam Assist automatically dips the headlights and prevents dazzle for oncoming vehicles, or vehicles travelling ahead. At night time at speeds of above 37mph, the system automatically switches the headlights to high-beam.

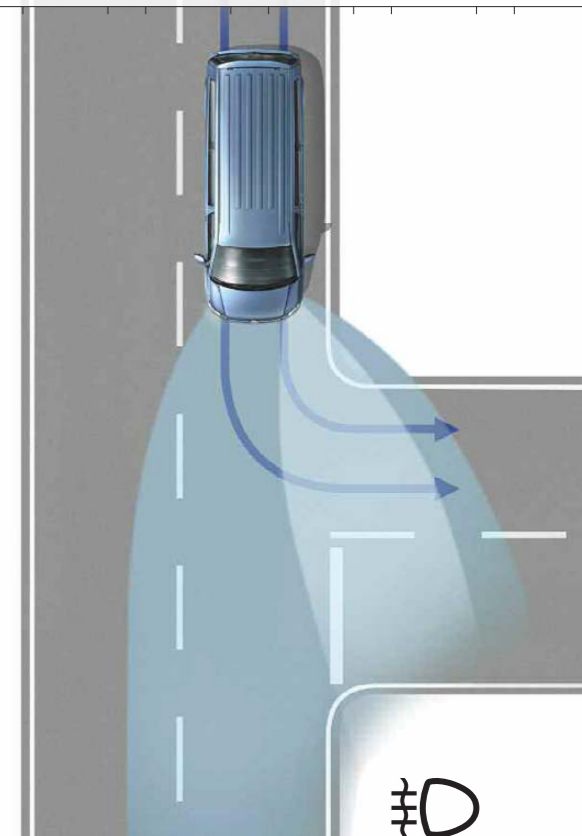

Fog lights with integrated cornering lights.
Available as an option, these help to illuminate curves and bends in the road ahead. This aids the driver in spotting any obstacles where the vehicle is turning.

Prepared for any scenario.

Advanced driver assistance systems.

The new Transporter is equipped with a number of systems – all of which are activated in critical situations as preventative measures. Add to this a variety of new and innovative driver assistance systems and you'll discover the new Transporter is prepared for any scenario.



01 Optional parking sensor display.



02 Optional rear-view camera display.



Cruise control.
Available as an option, cruise control maintains the selected speed, or limits the top speed to a value set by the driver.



Driver Alert System.
Fitted as standard, the Driver Alert System registers deviation from normal steering patterns and uses visual and acoustic warnings to recommend that the driver takes a break.



Brake Assist.
Fitted as standard, the system registers the speed at which the brake pedal is pressed. During emergency braking, it ensures full brake pressure is applied more quickly.



Daytime running lights.
Fitted as standard, daytime running lights offer extra safety. For convenience, they are automatically switched on when you start your vehicle.



Hill Hold Assist.
The standard Hill Hold Assist prevents your vehicle from rolling back when pulling away on an incline. The hold operates for approximately two seconds.



Tyre pressure monitoring.
The optional tyre pressure monitoring display (standard on kombi) activates a warning signal to highlight significant changes in tyre pressure. This lets the driver know that the tyre pressure should be checked as soon as possible.

EURO 5

2.0 litre TDI 84PS (62kW)¹
 Average consumption: 42.2mpg
 CO₂ emissions: from 176g/km
 Maximum torque: 220Nm

2.0 litre TDI 140PS (103kW)¹
 Average consumption: 40.4mpg
 CO₂ emissions: from 184g/km
 Maximum torque: 340Nm

2.0 litre TDI 102 PS (75kW)¹
 Average consumption: 42.2mpg
 CO₂ emissions: from 176g/km
 Maximum torque: 250Nm

2.0 litre BiTDI 180PS (132kW)¹
 Average consumption: 39.8mpg
 CO₂ emissions: from 187g/km
 Maximum torque: 400Nm

EURO 6

2.0 litre TDI 102PS (75kW)¹
 Average consumption: 47.9mpg
 CO₂ emissions: from 153g/km
 Maximum torque: 250Nm

More powerful. More economical. More advanced.
The new engines with the Euro 6 emissions standard.

Powerful, economical and advanced. Our latest generation TDI and BiTDI common-rail direct injection diesel engines provide excellent economy and an abundance of usable torque for shifting heavy loads. BlueMotion Technology is standard across the range.

Depending on your engine choice, you'll receive a 5 or 6-speed manual gearbox as standard, while the Euro 5 140PS and 180PS engines can be specified with a dual clutch direct shift gearbox (DSG), providing a smooth power-flow when changing gear.

Our most **economical** engines ever.



More mpg. Less CO₂.

A comparison between the previous 102PS TDI diesel engine and our new Euro 5 and Euro 6 102PS TDI diesel engines with BlueMotion Technology.

New Euro 5 102PS.¹

Economy mpg	CO ₂ g/km
+4.5	-22

New Euro 6 102PS.¹

Economy mpg	CO ₂ g/km
+10.2	-45

¹ Fuel and CO₂ figures are for illustrative purposes. Please see pages 42-43 for more details. Figures are based on Panel van Startline, manual, front wheel drive derivatives.

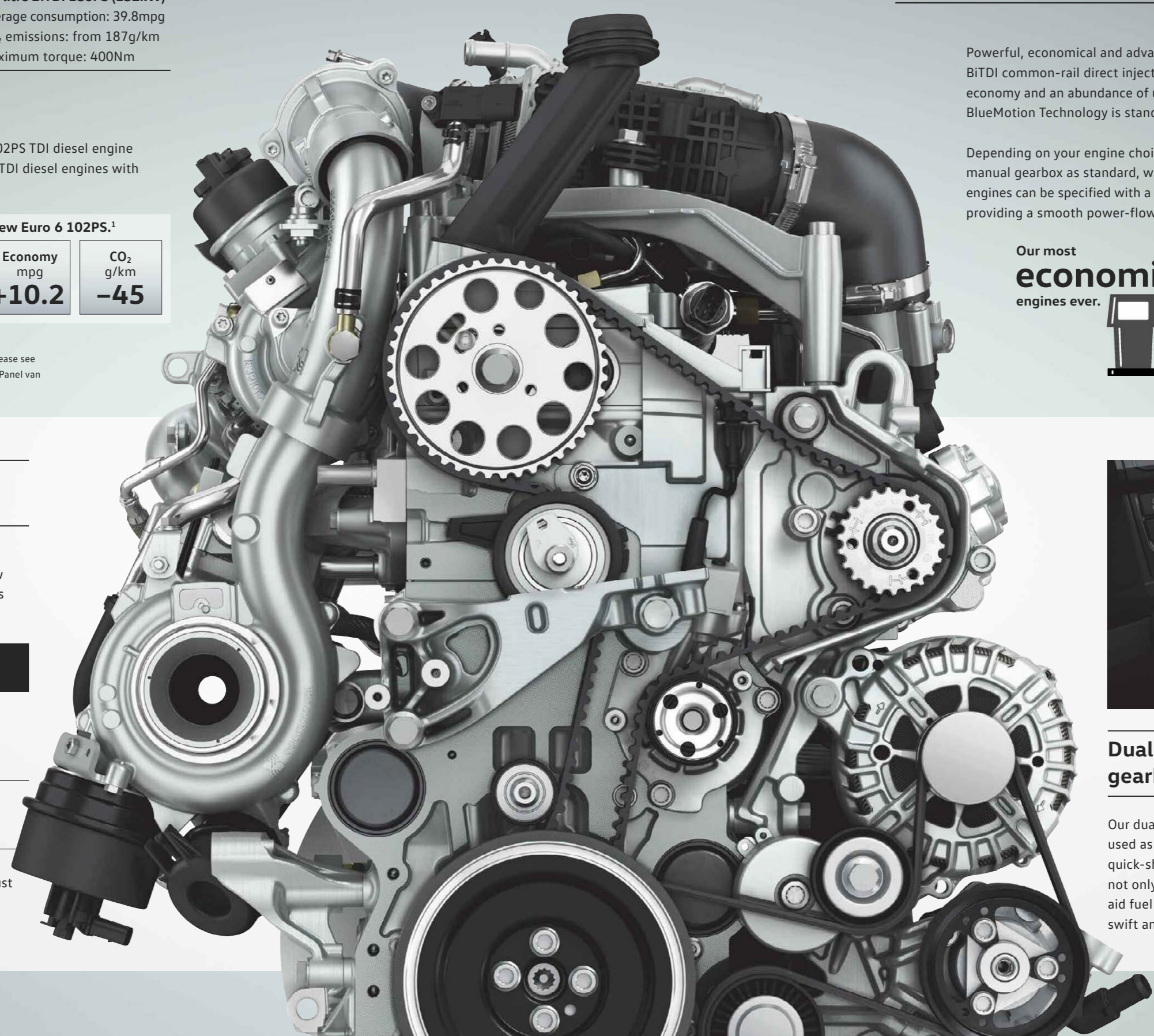

Euro 6 engines. Volkswagen leading the way.

With emission standards becoming increasingly tougher, we're already one step ahead. The all new Transporter Euro 6 engines deliver lower emissions and higher residual values.

Euro 6 is achieved by applying the following technologies:

Selective Catalytic Reduction (SCR).

Converts Nitrogen Oxide (NO_x) into Nitrogen by the addition of ammonia to the exhaust system. Uses AdBlue® stored in a 13 litre tank.

Exhaust Gas Recirculation (EGR).

Reduces harmful Nitrogen Oxide (NO_x) by recirculating cooled exhaust gases.

Diesel Particulate Filter (DPF).

Captures soot and particulates. Once full, the exhaust temperature increases to burn and remove soot.



Dual clutch direct shift gearbox (DSG).

Our dual clutch direct shift gearbox (DSG) can be used as a fully automatic gearbox, or as a responsive quick-shift manual. The innovative dual clutch system not only facilitates an instant gear change, but can aid fuel consumption, whilst also helping to maintain swift and smooth progress.

BLUEMOTION
 TECHNOLOGY

Delivering miles more.

BlueMotion Technology.

Designed to benefit the pocket of your business, BlueMotion Technology (BMT) is standard on every model in the Transporter range. BMT consists of three key elements, namely Start/Stop, low rolling resistance tyres and regenerative braking. Together, they contribute to significant improvements in fuel consumption and CO₂ emissions. As an example, the amazing Euro 6 2.0 litre 102PS TDI panel van utilises 250Nm maximum torque and delivers a combined fuel figure of **47.9mpg¹**. This enables you to travel further on a single tank with CO₂ emissions of just **153g/km**. It's the perfect balance of power, torque and economy.

Up to:
47.9
 mpg
 combined cycle
 fuel consumption.



BlueMotion Technology. Benefit your pocket and the environment.

Standard on all Euro 5 and Euro 6 TDI and BiTDI diesel engines, BlueMotion Technology consists of three key elements.

Start/Stop.

Allows you to save fuel by automatically turning the engine off when you stop and engage neutral. As soon as it's time to move, the engine starts up again. A simple, but highly-effective system.

Low rolling resistance tyres.

These don't need to work as hard to get your vehicle moving (and keep it rolling) which is especially useful when shifting heavy loads. This reduces engine work, saves fuel and lowers CO₂ emissions.

Regenerative braking.

When you brake, the energy recuperation system uses momentum to turn the alternator and charge the battery. A well charged battery results in the engine doing less work, which in-turn saves fuel and lowers CO₂ emissions.



01 Start/Stop – a key element of BlueMotion Technology.

¹ Fuel and CO₂ figures are for illustrative purposes. Please see pages 42-43 for more details. Figures are based on panel van Startline, manual, front wheel drive derivatives.



Get to grips with hard work.

4MOTION all-wheel drive.

The new Transporter offers a number of innovative features to help retain traction, optimum handling and outstanding steering response when encountering poor surface conditions.

A new generation of 4MOTION all-wheel drive.

The advantages of the new Haldex clutch for the optional 4MOTION all-wheel drive include reduced weight, a decrease in fuel consumption and an improvement to vehicle handling and dynamics.

4MOTION all-wheel drive with DSG.

The new Transporter is the only vehicle in its class that's available with 4MOTION all-wheel drive and a 7-speed, dual clutch direct shift gearbox (DSG). Available as an option, this combination enables smooth driving on rugged terrain, thanks to its fully automatic gear changes.

Hill Descent Control.

This useful option allows you to drive down steep slopes in a safe and controlled manner, thanks to the engine management's ability to govern the engine speed and apply the brakes if necessary. The vehicle's speed is maintained at a steady pace, without the driver needing to have additional input.

Mechanical differential lock.

The mechanical differential lock is available for the rear axle together with the optional 4MOTION all-wheel drive. This helps to maintain traction when you encounter adverse conditions, such as rain, snow, mud or gravel.

Wading depth.¹



300mm

Ramp angle.²



14°

Approach and departure angles.²



17°

21°

Hill climbing ability.³

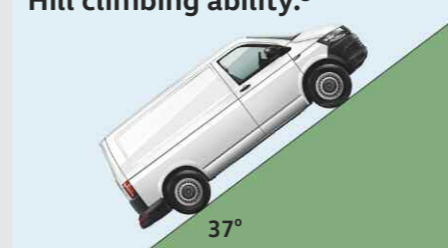

37°

¹ Measured with a full load and max. 18mph.

² Measured with standard equipment and a full load.

³ Measured with a 180PS BiTDI engine and a vehicle weight of 3.0t.

Designed to make work easier.
Rear door solutions.

The new Transporter offers two wheelbases and three roof heights, so there's no need to compromise when it comes to space or access. With its legendary build-quality, together with robust hinges and handles, all Transporters are designed to take the rigours of the working day in their stride. We know that flexibility is important for any business, so every Transporter is available with a choice of either a large tailgate, or versatile rear wing doors - with the option to specify 250° opening angle hinges. Both are available glazed or in solid metal for maximum security. With a low load bed, combined with a maximum opening width of 1,473mm and maximum load height of 1,940mm, you'll discover that whichever solution you choose, the Transporter is designed to make work easier.

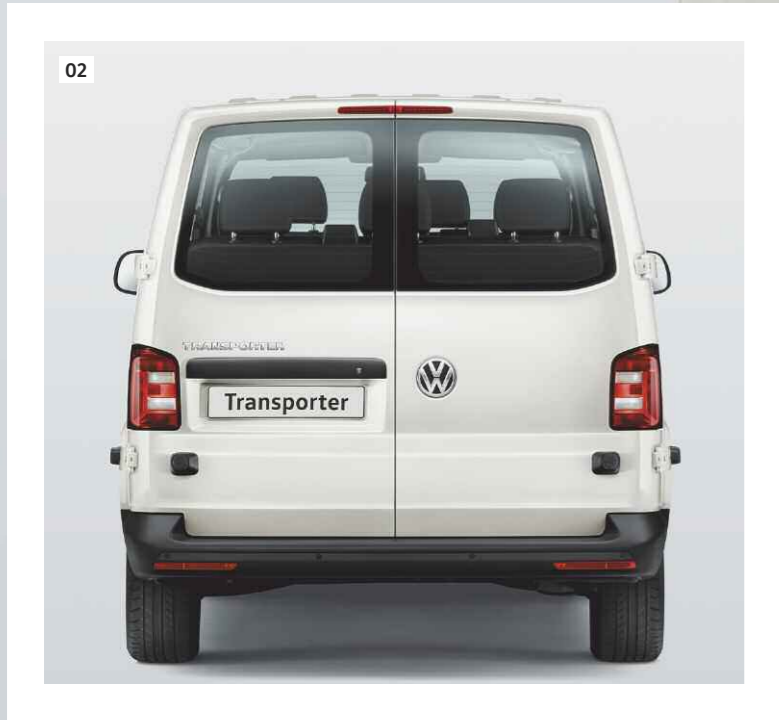

Rear wing doors
250°
 opening angle with
 secure latch.



01 Main image features rear wing doors without windows which are standard on panel van, while optional on kombi. Image also shows optional 250° opening angle hinges.

02 Rear wing doors with heated windows - optional on panel van and kombi.
03 Tailgate with window - standard on kombi, no-cost option on panel van.
04 Tailgate without window - no-cost option for panel van and kombi.

05 Optional high roof featuring high rear wing doors with windows.
06 Optional high roof featuring high rear wing doors without windows.



The space to tackle large and difficult jobs.
Load space solutions.

All new Transporter models provide a spacious load compartment with volumes ranging from 5.8m³ for the short wheelbase low roof, to 9.3m³ for the long wheelbase high roof. If you require the flexibility to carry both cargo and crew, then the versatile kombi is the answer. With its rear seats removed, the kombi offers near identical levels of usable space. While the standard specification includes multiple load-lashing rings, sturdy painted load floors on panel vans and rubber floor coverings on the kombi, it's the Transporter's range of optional bulkheads, robust load floor coverings, storage solutions, ventilation and electrical upgrades – not to mention its range of Volkswagen accessory 'Add Ons', that help it to tackle virtually any job.



- 01 Optional rubber load floor covering (standard on kombi) with load-lashing rings.
- 02 Optional wooden load floor covering.
- 03 Optional metal side-lashing rails.
- 04 Optional full-height bulkhead with window.
- 05 Optional half-height bulkhead.
- 06 Optional load compartment heating system.
- 07 Optional load compartment roof ventilation.

So which model do you need?

Choose your van.

Short wheelbase low roof.

Load length: 2,572mm
Load width: 1,700mm
Load height: 1,410mm

5.8m³
load area volume.



Short wheelbase medium roof.

Load length: 2,572mm
Load width: 1,700mm
Load height: 1,635mm

6.7m³
load area volume.



Long wheelbase low roof.

Load length: 2,975mm
Load width: 1,700mm
Load height: 1,410mm

6.7m³
load area volume.



Long wheelbase medium roof.

Load length: 2,975mm
Load width: 1,700mm
Load height: 1,635mm

7.8m³
load area volume.

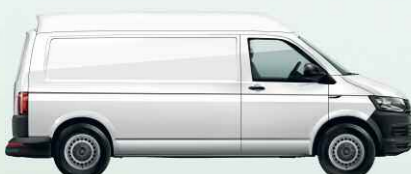

Long wheelbase high roof.

Load length: 2,975mm
Load width: 1,700mm
Load height: 1,940mm

9.3m³
load area volume.



Our range of
spacious
compact vans.

How to select your van:

1. Think about the **maximum length and height** of your load. This will help you choose a wheelbase and roof height. If you need to carry more than two passengers, you'll need to consider choosing a Transporter kombi.
2. On the right hand page you'll see **payload** ranges. Think about the heaviest load you need to carry. This will help you choose what's suitable (for instance a T30).
3. From the choice available, decide on your **trimline**.
4. Take a look at the separate Transporter price list to discover which **engines and options** are available for your chosen van.

Exterior dimensions.

2,476mm – high roof height.

2,176mm – medium roof height.

1,990mm – low roof height.

4,892mm – short wheelbase length.

5,292mm – long wheelbase length.



Panel van.

T26 (2,600kg) T28 (2,800kg) T30 (3,000kg) T32 (3,200kg) T30 (3,000kg) T32 (3,200kg)

Short wheelbase low roof.

Trimline:	Trimline:	Trimline:	Trimline:	Trimline:	Trimline:
SL TL HL	SL TL HL	SL TL HL	SL TL HL	SL TL HL	SL TL HL
Payload: 658kg – 745kg	Payload: 807kg – 945kg	Payload: 1,007kg – 1,145kg	Payload: 1,063kg – 1,331kg	Payload: 806kg – 1,048kg	Payload: 987kg – 1,224kg

Short wheelbase medium roof.

Trimline:	Trimline:	Trimline:	Trimline:	Trimline:
SL TL HL	SL TL HL	SL TL HL	SL TL HL	SL TL HL
Payload: 807kg – 945kg	Payload: 1,007kg – 1,145kg	Payload: 1,063kg – 1,331kg	Payload: 806kg – 1,048kg	Payload: 987kg – 1,224kg

Long wheelbase low roof.

Trimline:	Trimline:	Trimline:	Trimline:
SL TL HL	SL TL HL	SL TL HL	SL TL HL
Payload: 750kg – 888kg	Payload: 950kg – 1,088kg	Payload: 1,007kg – 1,274kg	Payload: 923kg – 1,171kg

Long wheelbase medium roof.

Trimline:	Trimline:	Trimline:	Trimline:
SL TL HL	SL TL HL	SL TL HL	SL TL HL
Payload: 750kg – 888kg	Payload: 950kg – 1,088kg	Payload: 1,007kg – 1,274kg	Payload: 923kg – 1,171kg

Long wheelbase high roof.

Trimline:	Trimline:	Trimline:	Trimline:
SL TL HL	SL TL HL	SL TL HL	SL TL HL
Payload: 750kg – 888kg	Payload: 950kg – 1,088kg	Payload: 1,007kg – 1,274kg	Payload: 923kg – 1,171kg

Key:

SL – Startline TL – Trendline HL – Highline

Your van.

You probably already have an idea about what you need from your ideal van and what you'll need to carry. Likewise, you're sure to have an idea about what's the heaviest, tallest, widest or longest load you'll need to get into your vehicle. If you're a fleet manager, then you'll probably need a variety of options and more than one vehicle. Bearing these factors in mind, the information featured on these pages is designed to help as a quick guide to which vehicle may be the closest match to your own specific requirements.

Your trimline.

For added choice, there's a variety of trimlines available, each delivering its own distinct feel. From the robust Startline to the luxurious Highline, you're sure to find a vehicle and trimline combination that not only works hard, but also creates the right impression.

Your choice.

And remember, that's not all. Every Transporter is available with a wide range of options and accessories – all designed to further help tailor your vehicle to your own particular needs. So which model do you need?

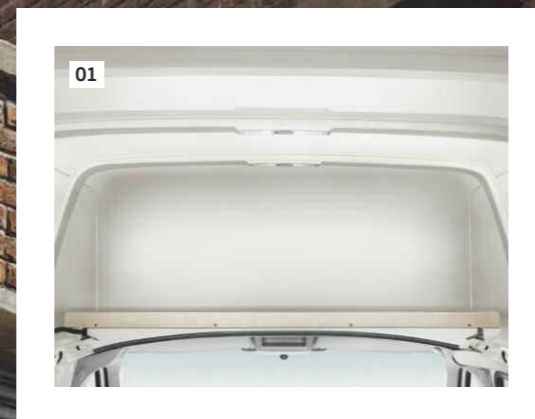

Short and long wheelbase with two or three seats.



Short wheelbase with standard dual passenger seat.



Long wheelbase with optional single passenger seat.

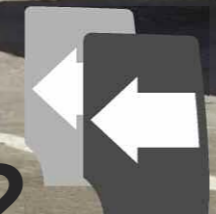

Up to **2** side sliding doors.

Exceeding expectations.

The new Transporter panel van.

Designed to exceed expectations, the new Transporter panel van is available with a choice of three roof heights, two wheelbases and five engines. This level of choice and adaptability means you can tailor your van precisely to the needs of your business. Standard cab seating consists of a single driver's seat with height, lumbar, reach and rake adjustment and a dual passenger seat with storage. There's also the option of a single passenger seat. Access to the cargo area is through a single near-side sliding door and twin rear wing doors without windows, while a second off-side sliding door can also be specified. To restrain your cargo, the floor area features either six or eight load-lashing rings (depending on you choice of wheelbase), ensuring your load is secured as safely as possible.

- 01 Medium and high roof models feature generous additional above-cab storage.
- 02 Storage compartment in dual passenger seat base.
- 03 The low roof panel van's roof storage compartment.

Perfect for cargo and crew alike.

The new Transporter kombi.

Versatility is at the core of every new Transporter kombi. With an identical choice of roof heights, wheelbases and engines to the panel van, the kombi features a single front passenger seat and adds to the panel van by offering removable rear seating for a further three passengers – all fitted with 3-point seatbelts and height-adjustable head restraints. Access to the rear passenger area is through a single near-side glazed sliding door, while at the rear there's a glazed tailgate with heated window and wash-wipe. Featuring a robust rubber floor covering throughout the cab and cargo area, as well as four load-lashing rings in the cargo area, the kombi's flexible interior can be transformed in seconds from a comfortable five or six-seater, into a spacious delivery van. It's the ideal choice when you need to combine load carrying with the ability to safely transport a crew of up to six (including the driver).

Short and long wheelbase with five or six seats.



Short wheelbase with standard single passenger seat.



Long wheelbase with optional dual passenger seat.



The versatility to
adapt
 to your needs.

Choose your trimline.

Startline equipment.

Audio and communications.

Bluetooth® phone connectivity with trip computer and multi-function display.
Composition Colour DAB radio system with 5" touch-screen, single MP3 compatible CD drive, SD card slot, AUX-IN socket and four speakers.
USB connection in glove compartment or storage shelf.

Cab area.

Austin cloth upholstery.
Digital clock.
Dimmable dashboard illumination.
Door mirrors – electrically heated and adjustable.
Driver's seat with height, lumbar, reach and rake adjustment.
Dual passenger seat with storage (panel van).
Electric front windows.
Gear shift indicator.
Interior light.
Lockable glove compartment.
Manually controlled heating system with dust and pollen filter and air recirculation.
Rev counter.
Rubber floor covering.
Single passenger seat with reach and rake adjustment (kombi).
Storage net on lower passenger side dash.
12v sockets x 2.

Cargo area.

Half-height load side lining in hardboard.
Interior entry step.
Interior roof trim in painted hardboard (low roof only).
Load-lashing rings (six for short wheelbase and eight for long wheelbase).
Rear door interior release lever.
Rubber floor covering (kombi).
Manual near-side sliding door.
Sliding windows in near-side sliding door and opposite window (kombi).
Steel flooring (panel van).
Three-seat bench in first row (kombi).
Two door activated interior lights (three with optional high roof).

Once you've found your ideal van – or indeed vans if you're a fleet customer, the next step is to choose your perfect trimline. Both the new Transporter panel van and kombi have a choice of three levels (**Startline**, **Trendline** and **Highline**) – each with their own particular strengths and all designed to create the right impression for your business.

Exterior.

Front and rear towing eyes.
Galvanised steel body.
Black door mirrors and handles.
Black front and rear bumpers.
Heat insulating glass.
Tailgate with heated window and wash-wipe (kombi).
Unglazed rear wing doors with 180° door opening (panel van).

Safety and security.

Anti-lock Braking System (ABS).
Automatic Post-Collision Braking System.
Brake Assist.
Driver Alert System.
Driver and passenger front airbags (with passenger deactivation).
Electronic Brakeforce Distribution (EBD).
Electronic Differential Lock (EDL).
Electronic Stabilisation Programme (ESP).
Height-adjustable head restraints.
Height and rake adjustable steering column.
Hill Hold Assist.
Remote central locking with interior locking, two remote folding keys and one rigid key.
Seatbelt warning when not engaged.
Thatcham Category 2 approved immobiliser.
Traction Control System (TCS).
Tyre pressure monitoring (kombi).

Wheels and tyres.

16 x 6.5J steel wheels.
Black wheel centre caps.
Full size steel spare wheel.
Tool kit and jack.
Euro 5 tyres – 215/65 R16 low rolling resistance.
Euro 6 tyres – 205/65 R16 low rolling resistance.

BlueMotion Technology.

BlueMotion Technology exterior badge.
Low rolling resistance tyres.
Regenerative braking.
Start/Stop.

01



02



04



06



03



05

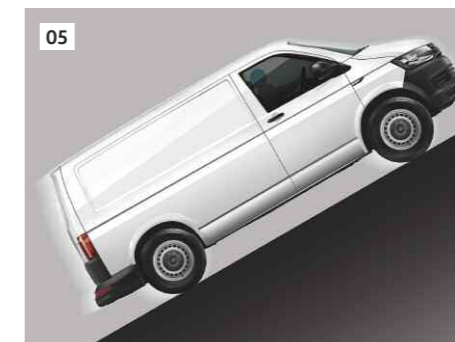

07



01 Halogen headlights. Efficient and attractive with range adjustment.
02 Steel wheels. Sturdy and strong with Black wheel centre caps.
03 Steel flooring in load compartment. Standard on all panel vans.

04 Rubber floor covering. Standard on kombi. Image also illustrates one of the multiple load-lashing rings.
05 Hill Hold Assist. Aids economical and smooth starts on inclines.

06 Black door mirrors and handles. Both robust and hard-wearing.
07 Composition Colour DAB radio system with 5" touch-screen. Standard on all new Transporter models.

Equipment in addition to Startline. Trendline equipment.

The **Trendline** equipment builds upon the strengths of the Startline by offering a wide range of stylish, practical and technological items. By selecting the most popular options available and combining them into one handy pack, the Trendline offers amazing value when compared to ordering each item individually.

Audio and communications.

Multi-function display 'Plus'.

Cab area.

Armrests for driver's seat.

Armrests for front passenger seat (kombi).

Comfort pack – including foldable grab handles on 'A' pillars, driver and front passenger seat side storage compartments, twin sun visors with vanity mirrors, two-tone horn, dimmable dashboard illumination and additional noise suppression measures.

Cruise control.

Simora cloth upholstery.

Cargo area.

Full-height steel bulkhead (panel van).

Exterior.

Body-coloured bumpers, door mirrors and handles.

Rear parking sensors.

Wheels and tyres.

Stylish full-width wheel trims.

Equipment in addition to Trendline. Highline equipment.

The luxurious **Highline** adds to the Trendline's already impressive specification and offers the perfect balance of comfort and style in a hard-working vehicle.

Choose a Highline and you'll have a van that's designed to help get your business noticed.

Cab area.

Automatically dimming rear-view mirror with rain sensor.

Automatic driving light control.

Climatic air conditioning.

Coming home and leaving home function.

Heated windscreen.

Leather multi-function steering wheel, gearknob and gaiter.

Exterior.

Daytime running lights.

Front fog lights with cornering function.

Safety and security.

Thatcham Category 1 approved alarm and immobiliser with tow-away, perimeter and interior cab protection.

Wheels and tyres.

16" Clayton alloy wheels.

17" Devonport alloy wheels (T32 and/or 180PS engine).

Euro 5 tyres.

215/65 R16 low rolling resistance.

235/55 R17 low rolling resistance (180PS).

215/60 R17 all-weather (T32).

Euro 6 tyres.

205/65 R16 low rolling resistance.

215/65 R17 low rolling resistance (T32).



01 Full-width wheel trims. An eye-catching and realistic alloy wheel-effect design.

02 Body-coloured bumpers, door mirrors and handles. Increased elegance for style-conscious businesses.

03 Armrests for driver's seat (panel van) and front passenger seat (kombi). Image features optional leatherette upholstery in Moonrock.

01 16" Clayton alloy wheels.
02 17" Devonport alloy wheels. Standard on T32 and/or 180PS engine.

03 Climatic air conditioning. Delivers a temperature controlled environment.
04 Fog lights with cornering lights. A stylish, safe and practical addition.

05 Leather multi-function steering wheel, gearknob and gaiter. Adds a touch of class to your Transporter's interior.

Solid paint.

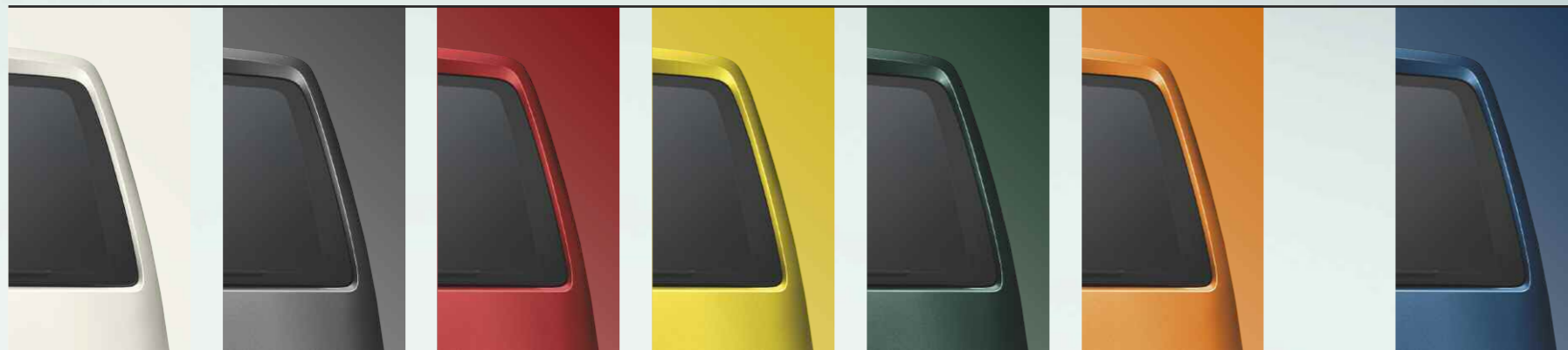

Candy White. Pure Grey. Cherry Red. Grape Yellow.¹ Ontario Green. Bright Orange. Deep Ocean.

Metallic paint.¹



Reflex Silver. Indium Grey. Mojave Beige. Chestnut Brown. Bamboo Garden Green. Acapulco Blue. Starlight Blue. Blackberry.

Pearl effect paint.¹



Oryx White.² Deep Black.

Interior trim.¹



Moonrock Grey. Titanium Black.

Seat upholstery.

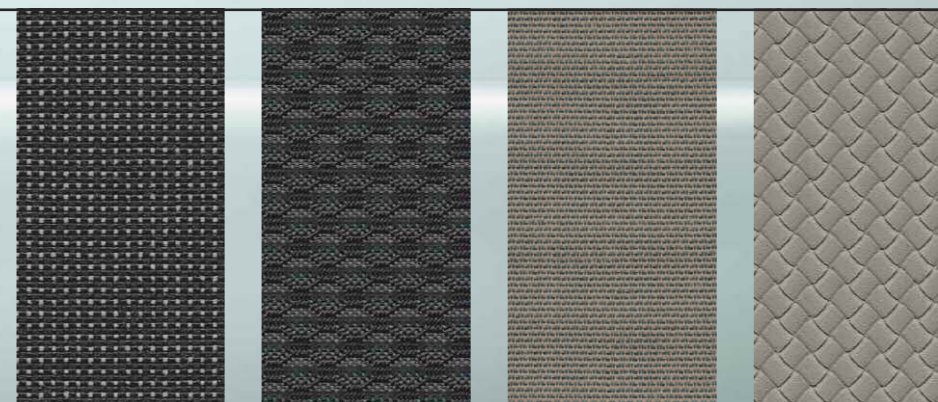

Austin.³ Titanium Black Cloth. **SL**
 Simora.¹ Titanium Black Cloth. **SL TL HL**
 Marathon.^{1,4} Moonrock Robust Cloth. **SL TL HL**
 Leatherette.¹ Moonrock Synthetic leather. **SL TL HL**

Key:

Standard **Optional**
 SL - Startline TL - Trendline HL - Highline

Paint, trim and upholstery.

Formulated to withstand all that work can throw at it, the new Transporter's paint, trim and upholstery are designed to stand the test of time. As you'd expect from any Volkswagen, exterior paints offer a smooth and tough finish, while the interior upholstery is made from high-quality materials that are both robust and easy to clean.

Please note: Not all paint and upholstery combinations can be ordered together and in some instances certain combinations may incur extra cost. Not all paint finishes may be available for every trimline. Please check details and availability with your Volkswagen Van Centre at the time of ordering. Print processes do not allow exact reproduction of paint and upholstery colours.

¹ Available at extra cost. ² Available at a later date only in conjunction with rear wing doors. ³ Also available in Moonrock. ⁴ Only available for the cab.

Wheels.

Steel wheel.

16 x 6.5J with 215/65 R16 or 205/65 R16 tyres.
Standard on Startline.

Clayton.

16 x 6.5J alloy wheels with 215/65 R16 or 205/65 R16 tyres.
Standard on Highline.

Cascavel.

17 x 7J alloy wheels with 235/55 R17 or 215/65/17 tyres.

Timaru.

17 x 7J alloy wheels with 235/55 R17 or 215/65/17 tyres.

Springfield.

Polished finish.
18 x 8J alloy wheels with 255/45 R18 tyres.

16"

Full wheel trim.

16 x 6.5J with 215/65 R16 or 205/65 R16 tyres.
Standard on Trendline.

17"

Devonport.

17 x 7J alloy wheels with 235/55 R17 or 215/65/17 tyres.
Standard on T32 and/or180PS Highline.

18"

Springfield.

18 x 8J alloy wheels with 255/45 R18 tyres.

Audio and communications.



Composition Colour DAB radio system.

Fitted as standard, the Composition Colour DAB radio system features a 5" TFT touch-screen colour display, USB port, Bluetooth®, SD card slot, AUX-IN interface, MP3 and WMA compatible CD drive, 4 x 20 watt output with two speakers and a dual tuner with PhaseDiversity for optimum radio reception.



Composition Media DAB radio system.

The optional Composition Media DAB radio system features an increased touch-screen size of 6.33" with proximity sensor, USB port, Bluetooth®, SD card slot, AUX-IN interface, MP3 and WMA compatible CD drive, 4 x 20 watt output with four speakers and a dual tuner with PhaseDiversity for optimum radio reception. App-Connect is available as an option for this system.



Discover Media satellite navigation system.

The optional Discover Media satellite navigation system builds on the strengths of the Composition Media DAB radio system by adding satellite navigation and a second integrated SD card slot compatible for map data. The system includes free updates for the pre-installed European maps through Volkswagen MapCare. App-Connect is available as an option for this system.

Mobile online services.

App-Connect – Volkswagen apps.¹

Special Volkswagen apps, such as 'Shared Audio', 'Drive & Track', 'Call & Remind', 'Sound Journey' and 'My Guide' make every journey more pleasant and interesting. The apps provide you with information about your driving behaviour, guide you to parking spaces in the vicinity, make detailed suggestions about exciting destinations – all taking into account the weather and traffic data.

Car-Net Guide & Inform.²

Use Car-Net Guide & Inform to enhance your vehicle's optional navigation system with online-based, up-to-date information services for greater convenience when travelling. For example, utilise real-time traffic information to avoid a sudden traffic jam, or refuel at the cheapest petrol station, or find a free parking space without the need for an infuriating search. Car-Net Guide & Inform ensures that you always reach your destination quickly and with the least possible stress.



Online traffic information.

Save time and avoid stress with real-time traffic information, enabling you to avoid traffic jams by dynamically adapting your route.



Petrol stations.

View the petrol stations with the cheapest fuel prices in your immediate vicinity. Your vehicle's fuel type is automatically identified.



Parking spaces.³

Save time and view available parking options, along with prices and opening hours.



Weather.

Stay up-to-date with the latest weather information while on the move.



Online special destination search.

Customised information about local services is sent directly to your touch-screen display.



News

Subscribe to personalised news categories and use the news feeds to stay up-to-date.



Online destination import.

Conveniently plan your driving destinations from home using the customer portal and retrieve them using the navigation system.



My special destinations.

Use the customer portal to save your preferred destinations while at home and import these into your vehicle's navigation system.



Vehicle status report.

Retrieve the latest service information and error messages from your vehicle.



Car-Net registration in a few easy steps:

1. Create your personal account on the Car-Net website.
2. You will receive a registration code (PIN).
3. Enter your vehicle identification number (VIN).
4. Enter the PIN into your vehicle's navigation system.

Engine and gearbox data.

Engine specifications.	2.0TDI 84PS	2.0TDI 102PS	2.0TDI 102PS	2.0TDI 140PS	2.0TDI 180PS
Engine type	Diesel, transverse, water-cooled, in-line, variable turbine geometry turbocharger with intercooler				Diesel, transverse, water-cooled, in-line, bi-turbo with intercooler
Mixture preparation/injection method	Common-rail, direct injection				
EU exhaust emission standard	EURO 5	EURO 5	EURO 6	EURO 5	EURO 5
Number of cylinders	4	4	4	4	4
Cubic capacity	1,968cc	1,968cc	1,968cc	1,968cc	1,968cc
Output, PS at rpm	84 at 3,500	102 at 3,500	102 at 3,750	140 at 3,500	180 at 4,000
Torque, max. Nm at rpm	220 at 1,250-2,500	250 at 1,500-2,500	250 at 1,500-2,750	340 at 1,750-2,500	400 at 1,500-2,000
Fuel tank capacity	80 litre	80 litre	70 litre	80 litre	80 litre
AdBlue® capacity	-	-	13 litre	-	-
Diesel Particulate Filter (DPF)	●	●	●	●	●
5-speed manual gearbox	●	●	●	-	-
6-speed manual gearbox	-	-	-	●	●
7-speed dual clutch gearbox (DSG)	-	-	-	○	○
Front-wheel drive	●	●	●	●	●
4MOTION all-wheel drive	-	-	-	○	○
BlueMotion Technology	●	●	●	●	●
Alternator	140A	140A	140A	140A	180A ¹
Battery	68Ah (380A)				

● Standard ○ Available - Not available

¹ All Highline models feature a 180A alternator.

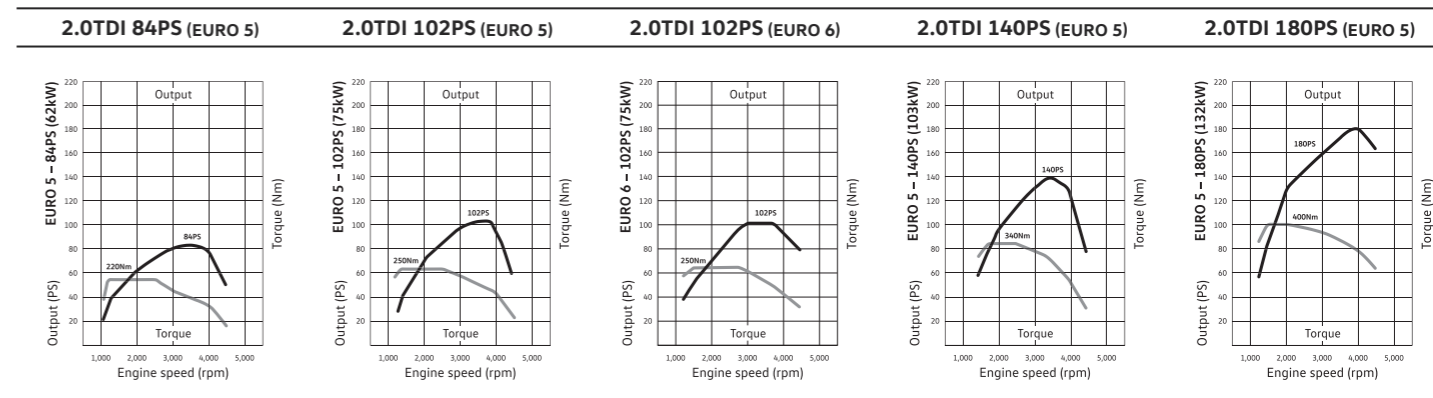

¹ App-Connect is only available in conjunction with the Composition Media DAB radio system or the Discover Media satellite navigation system. App-Connect comprises MirrorLink™, CarPlay™ and Android Auto™. The availability of these technologies can vary depending on the country in question. Please note that App-Connect is not currently supported by all mobile telephones on the market. Volkswagen is working closely with major smartphone producers to promote broader compatibility for App-Connect.

² The use of mobile online services (Car-Net) is only available in conjunction with the Discover Media satellite navigation system. You will also require a mobile device that is capable of acting as a mobile wireless hotspot. Car-Net services are only available with an existing mobile network contract or one to be agreed separately for this purpose between you and your mobile phone network provider and only within the respective mobile phone network coverage. Depending on your mobile phone tariff, receiving data from the internet may incur additional charges, particularly if you are using the phone abroad. Due to the amount of data needed when using Car-Net services, we strongly recommend signing-up to a data flat rate with your mobile phone provider. Use of Car-Net is governed in a separate agreement with Volkswagen AG online. After taking possession of the vehicle, you have 90 days in which to register the vehicle at www.volkswagen-commercial-vehicles-carnet.com. The availability of Car-Net services may vary depending on the country in question. These services are available for the duration of the contract term agreed and may be subject to changes in terms of content during the contract period. More detailed information on Car-Net is available at www.volkswagen-commercial-vehicles-carnet.com and from your Volkswagen Commercial Vehicles Van Centre. Contact your mobile network provider for information regarding your mobile network tariff.

³ Available for car parks compatible with the service.

Panel van economy and performance.

Engine	Urban mpg (ltr/100km) ¹	Extra-urban mpg (ltr/100km) ¹	Combined mpg (ltr/100km) ¹	Acceleration 0-62 mph seconds	Top speed (where law permits) mph	CO ₂ emissions g/km ¹
T26, T27, T28, T30 and T32 short and long wheelbase with low roof.						
2.0TDI 84PS EU5 BMT 5-speed manual	34.0 (8.3)	48.7 (5.8)	42.2 (6.7)	19.7	91	176
2.0TDI 102PS EU5 BMT 5-speed manual	34.0 (8.3)	48.7 (5.8)	42.2 (6.7)	15.3	98	176
2.0TDI 102PS EU6 BMT 5-speed manual	40.4 (7.0)	54.3 (5.2)	47.9 (5.9)	15.3	98	153
2.0TDI 140PS EU5 BMT 6-speed manual	31.7 (8.9)	47.9 (5.9)	40.4 (7.0)	12.2	107	184
2.0TDI 140PS EU5 BMT 7-speed DSG	30.4 (9.3)	43.5 (6.5)	37.7 (7.5)	12.5	107	198
2.0TDI 140PS EU5 4MOTION BMT 6-speed manual	28.8 (9.8)	42.2 (6.7)	36.2 (7.8)	13.5	106	206
2.0BiTDI 180PS EU5 BMT 6-speed manual	32.5 (8.7)	45.6 (6.2)	39.8 (7.1)	9.9	119	187
2.0BiTDI 180PS EU5 BMT 7-speed DSG	32.1 (8.8)	40.9 (6.9)	37.2 (7.6)	10.0	119	199
2.0BiTDI 180PS EU5 4MOTION BMT 6-speed manual	29.4 (9.6)	40.9 (6.9)	35.8 (7.9)	10.4	117	206
2.0BiTDI 180PS EU5 4MOTION BMT 7-speed DSG	29.1 (9.7)	37.7 (7.5)	34.0 (8.3)	10.6	117	219

T28, T30 and T32 short and long wheelbase with medium roof.

2.0TDI 84PS EU5 BMT 5-speed manual	34.0 (8.3)	48.7 (5.8)	42.2 (6.7)	19.8	88	176
2.0TDI 102PS EU5 BMT 5-speed manual	34.0 (8.3)	48.7 (5.8)	42.2 (6.7)	15.4	94	176
2.0TDI 102PS EU6 BMT 5-speed manual	40.4 (7.0)	54.3 (5.2)	47.9 (5.9)	15.4	94	153
2.0TDI 140PS EU5 BMT 6-speed manual	31.7 (8.9)	47.9 (5.9)	40.4 (7.0)	12.3	104	184
2.0TDI 140PS EU5 BMT 7-speed DSG	30.4 (9.3)	43.5 (6.5)	37.7 (7.5)	12.6	103	198
2.0TDI 140PS EU5 4MOTION BMT 6-speed manual	28.8 (9.8)	42.2 (6.7)	36.2 (7.8)	13.6	102	206
2.0BiTDI 180PS EU5 BMT 6-speed manual	32.5 (8.7)	45.6 (6.2)	39.8 (7.1)	10.0	114	187
2.0BiTDI 180PS EU5 BMT 7-speed DSG	32.1 (8.8)	40.9 (6.9)	37.2 (7.6)	10.1	114	199
2.0BiTDI 180PS EU5 4MOTION BMT 6-speed manual	29.4 (9.6)	40.9 (6.9)	35.8 (7.9)	10.5	113	206
2.0BiTDI 180PS EU5 4MOTION BMT 7-speed DSG	29.1 (9.7)	37.7 (7.5)	34.0 (8.3)	10.7	113	219

T28, T30 and T32 long wheelbase with high roof.

2.0TDI 84PS EU5 BMT 5-speed manual	33.6 (8.4)	44.1 (6.4)	39.8 (7.1)	20.3	85	187
2.0TDI 102PS EU5 BMT 5-speed manual	33.2 (8.5)	43.5 (6.5)	39.2 (7.2)	15.0	94	190
2.0TDI 140PS EU5 BMT 6-speed manual	31.0 (9.1)	43.5 (6.5)	38.2 (7.4)	12.7	100	195
2.0TDI 140PS EU5 BMT 7-speed DSG	30.4 (9.3)	40.4 (7.0)	36.2 (7.8)	13.0	99	206
2.0TDI 140PS EU5 4MOTION BMT 6-speed manual	28.5 (9.9)	39.8 (7.1)	34.9 (8.1)	14.0	98	214
2.0BiTDI 180PS EU5 BMT 6-speed manual	31.7 (8.9)	40.9 (6.9)	37.2 (7.6)	10.3	109	199
2.0BiTDI 180PS EU5 BMT 7-speed DSG	32.1 (8.8)	38.7 (7.3)	35.8 (7.9)	10.4	109	208
2.0BiTDI 180PS EU5 4MOTION BMT 6-speed manual	29.4 (9.6)	38.2 (7.4)	34.4 (8.2)	10.8	108	216

Kombi economy and performance.

Engine	Urban mpg (ltr/100km) ¹	Extra-urban mpg (ltr/100km) ¹	Combined mpg (ltr/100km) ¹	Acceleration 0-62 mph seconds	Top speed (where law permits) mph	CO ₂ emissions g/km ¹
T28, T30 and T32 short and long wheelbase with low roof.						
2.0TDI 84PS EU5 BMT 5-speed manual	34.0 (8.3)	48.7 (5.8)	42.2 (6.7)	19.7	91	176
2.0TDI 102PS EU5 BMT 5-speed manual	32.8 (8.6)	46.3 (6.1)	40.4 (7.0)	15.3	98	184
2.0TDI 102PS EU6 BMT 5-speed manual	38.2 (7.4)	51.4 (5.5)	45.6 (6.2)	15.3	98	162
2.0TDI 140PS EU5 BMT 6-speed manual	31.0 (9.1)	46.3 (6.1)	39.2 (7.2)	12.2	107	189
2.0TDI 140PS EU5 BMT 7-speed DSG	29.7 (9.5)	42.2 (6.7)	36.7 (7.7)	12.5	107	203
2.0TDI 140PS EU5 4MOTION BMT 6-speed manual	28.8 (9.8)	42.2 (6.7)	36.2 (7.8)	13.5	106	206
2.0BiTDI 180PS EU5 BMT 6-speed manual	31.7 (8.9)	44.1 (6.4)	38.7 (7.3)	9.9	119	192
2.0BiTDI 180PS EU5 BMT 7-speed DSG	32.1 (8.8)	40.9 (6.9)	37.2 (7.6)	10.0	119	195
2.0BiTDI 180PS EU5 4MOTION BMT 6-speed manual	29.4 (9.6)	40.9 (6.9)	35.8 (7.9)	10.4	117	208
2.0BiTDI 180PS EU5 4MOTION BMT 7-speed DSG	29.1 (9.7)	37.7 (7.5)	34.0 (8.3)	10.6	117	219

T28, T30 and T32 short and long wheelbase with medium roof.

2.0TDI 84PS EU5 BMT 5-speed manual	34.0 (8.3)	48.7 (5.8)	42.2 (6.7)	19.8	88	176
2.0TDI 102PS EU5 BMT 5-speed manual	32.8 (8.6)	46.3 (6.1)	40.4 (7.0)	15.4	94	184
2.0TDI 102PS EU6 BMT 5-speed manual	38.2 (7.4)	51.4 (5.5)	45.6 (6.2)	15.4	94	162
2.0TDI 140PS EU5 BMT 6-speed manual	31.0 (9.1)	46.3 (6.1)	39.2 (7.2)	12.3	104	189
2.0TDI 140PS EU5 BMT 7-speed DSG	29.7 (9.5)	42.2 (6.7)	36.7 (7.7)	12.6	103	203
2.0TDI 140PS EU5 4MOTION BMT 6-speed manual	28.8 (9.8)	42.2 (6.7)	36.2 (7.8)	13.6	102	206
2.0BiTDI 180PS EU5 BMT 6-speed manual	31.7 (8.9)	44.1 (6.4)	38.7 (7.3)	10.0	114	192
2.0BiTDI 180PS EU5 BMT 7-speed DSG	32.1 (8.8)	40.9 (6.9)	37.2 (7.6)	10.1	114	195
2.0BiTDI 180PS EU5 4MOTION BMT 6-speed manual	29.4 (9.6)	40.9 (6.9)	35.8 (7.9)	10.5	113	208
2.0BiTDI 180PS EU5 4MOTION BMT 7-speed DSG	29.1 (9.7)	37.7 (7.5)	34.0 (8.3)	10.7	113	219

T28, T30 and T32 long wheelbase with high roof.

2.0TDI 102PS EU5 BMT 5-speed manual	32.5 (8.7)	42.2 (6.7)	38.2 (7.4)	15.0	94	195
2.0TDI 140PS EU5 BMT 6-speed manual	30.4 (9.3)	42.2 (6.7)	37.2 (7.6)	12.7	100	199
2.0TDI 140PS EU5 BMT 7-speed DSG	29.7 (9.5)	39.2 (7.2)	35.3 (8.0)	13.0	99	211
2.0TDI 140PS EU5 4MOTION BMT 6-speed manual	28.5 (9.9)	39.8 (7.1)	34.9 (8.1)	14.0	98	214
2.0BiTDI 180PS EU5 BMT 6-speed manual	31.7 (8.9)	40.9 (6.9)	37.2 (7.6)	10.3	109	199
2.0BiTDI 180PS EU5 BMT 7-speed DSG	32.1 (8.8)	38.7 (7.3)	35.8 (7.9)	10.4	109	208
2.0BiTDI 180PS EU5 4MOTION BMT 6-speed manual	29.4 (9.6)	38.2 (7.4)	34.4 (8.2)	10.8	108	216

¹ The fuel consumption and emission values listed here have been ascertained in accordance with the legally stipulated measuring method. These figures do not refer to a particular specific vehicle and do not constitute part of the offer but are purely for comparison purposes between the various types of vehicle. In addition to the fuel efficiency of a vehicle, driving behaviour as well as other non-technical factors (such as environmental conditions) play a role in determining a vehicle's fuel consumption and CO₂ emissions. In addition to weather and traffic conditions, extra equipment and accessories (attachment parts, tyres, etc.) may change vehicle parameters such as the weight, rolling resistance of the tyres and the aerodynamics and thus influence the fuel consumption and driving performance values.

Panel van dimensions.

Short wheelbase low and medium roof.

Roof height	low	medium ¹
Wheelbase	3,000	3,000
Load compartment	length	2,572
	width	1,700
	width between	1,244
	wheel arches	
	height	1,410
	4.3m ²	4.3m ²
	5.8m ³	6.7m ³
Side sliding door	width	1,017
	height	1,282
Rear wing doors	width	1,473
	height	1,305
Tailgate	width	1,473
	height	1,299
Turning circle (wall to wall)	11.9m	11.9m

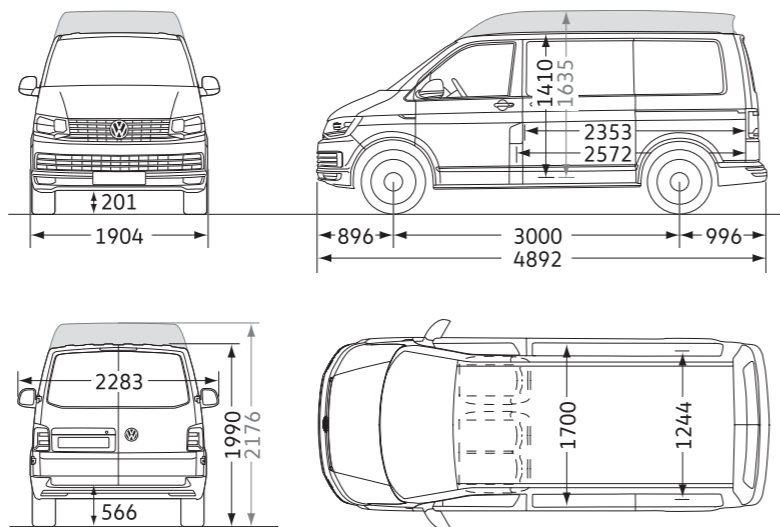

Kombi dimensions.

Short wheelbase low and medium roof.

Roof height	low	medium ¹
Wheelbase	3,000	3,000
Load compartment	length	2,572
	length behind	1,600
	rear seats	
	width	1,627
	width between	1,244
	4.3m ²	4.3m ²
	5.8m ³	6.7m ³
Side sliding door	width	1,017
	height	1,264
Rear wing doors	width	1,473
	height	1,305
Tailgate	width	1,473
	height	1,290
Turning circle (wall to wall)	11.9m	11.9m

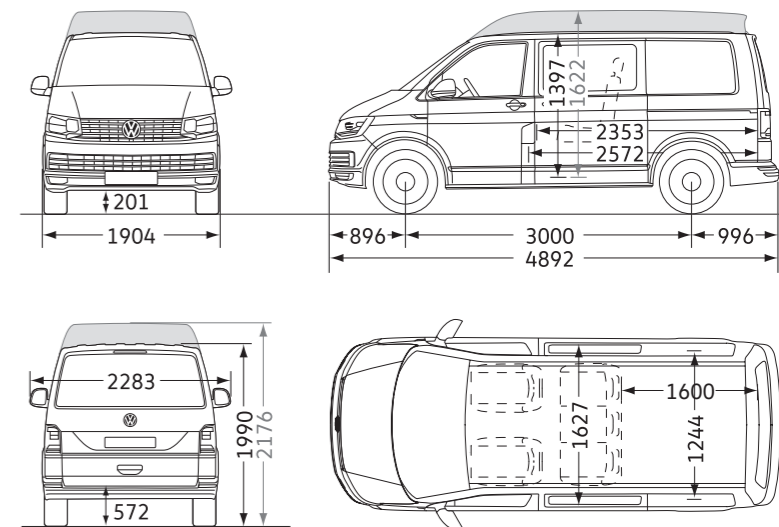

Long wheelbase low, medium and high roof.

Roof height	low	medium ¹	high ¹
Wheelbase	3,400	3,400	3,400
Load compartment	length	2,975	2,975
	width	1,700	1,700
	width between	1,244	1,244
	wheel arches		
	height	1,410	1,635
	5.0m ²	5.0m ²	5.0m ²
	6.7m ³	7.8m ³	9.3m ³
Side sliding door	width	1,017	1,017
	height	1,282	1,282
Optional high	width	-	1,017
	side sliding door	height	-
Rear wing doors	width	1,473	1,473
	height	1,305	1,694
Tailgate	width	1,473	-
	height	1,299	-
Turning circle (wall to wall)	13.2m	13.2m	13.2m

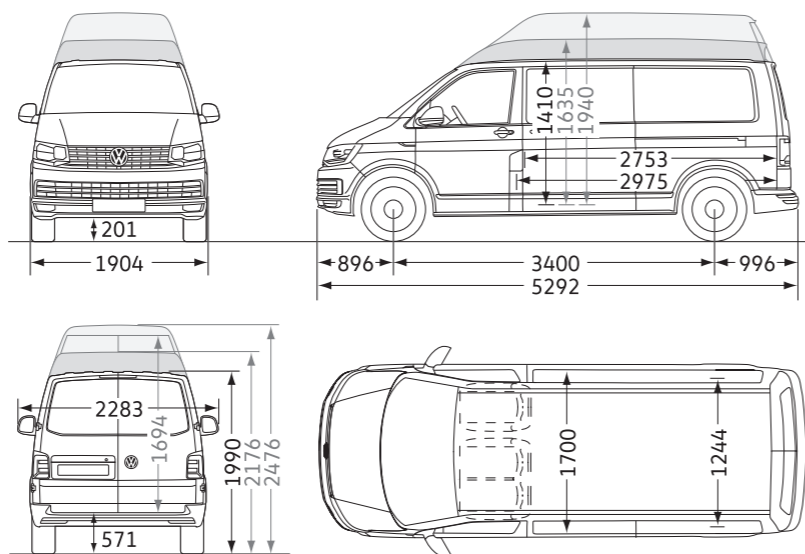

Long wheelbase low, medium and high roof.

Roof height	low	medium ¹	high ¹
Wheelbase	3,400	3,400	3,400
Load compartment	length	2,938	2,938
	length behind	1,967	1,967
	rear seats		
	width	1,627	1,627
	width between	1,244	1,244
	5.0m ²	5.0m ²	5.0m ²
	6.7m ³	7.8m ³	9.3m ³
Side sliding door	width	1,017	1,017
	height	1,264	1,264
Optional high	width	-	1,017
	side sliding door	height	-
Rear wing doors	width	1,473	1,473
	height	1,305	1,694
Tailgate	width	1,473	-
	height	1,290	-
Turning circle (wall to wall)	13.2m	13.2m	13.2m

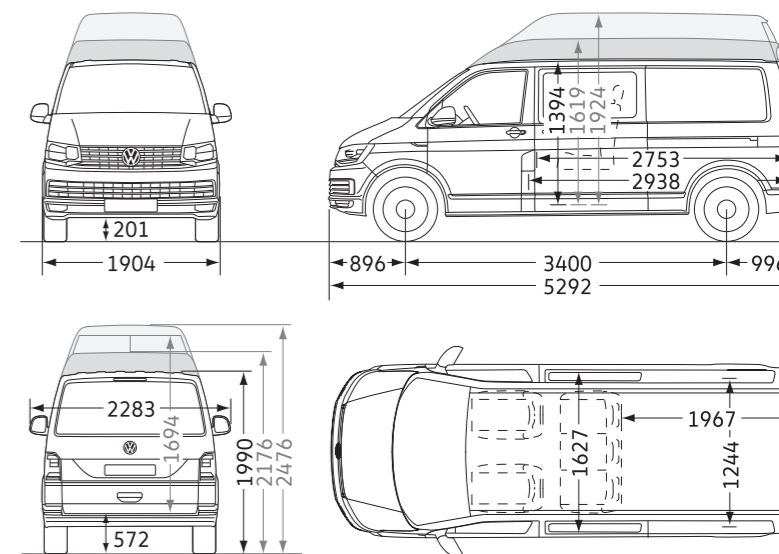

¹ Indicates optional medium or high roof.

Please note: Vehicle drawings are not to scale. All dimensions in millimeters (mm), unless otherwise stated. The height measurements listed may vary by ± 50mm depending on model and equipment fitted.

Panel van weights.

Model	Engine	Gross vehicle weight kg	Axle load limit front/rear kg	Trailer weight braked 12%/ unbraked kg	Gross train weight kg	Unladen weight ¹ kg	Payload ² kg	Unladen weight ¹ kg	Payload ² kg	Unladen weight ¹ kg	Payload ² kg
Short wheelbase.											
						Startline		Trendline		Highline	
T26	2.0TDI 84PS EU5 BMT 5-speed manual	2,600	1450 / 1400	2200 / 750	4,800	1,855	745	-	-	-	-
	2.0TDI 102PS EU5 BMT 5-speed manual	2,600	1450 / 1400	2200 / 750	4,800	1,855	745	1,887	713	1,916	684
	2.0TDI 102PS EU6 BMT 5-speed manual	2,600	1450 / 1400	2200 / 750	4,800	1,882	718	1,914	686	1,942	658
T28	2.0TDI 84PS EU5 BMT 5-speed manual	2,800	1500 / 1550	2200 / 750	4,800	1,855	945	-	-	-	-
	2.0TDI 102PS EU5 BMT 5-speed manual	2,800	1500 / 1550	2200 / 750	4,900	1,855	945	1,887	913	1,916	884
	2.0TDI 102PS EU6 BMT 5-speed manual	2,800	1500 / 1550	2200 / 750	4,900	1,882	918	1,914	886	1,942	858
	2.0TDI 140PS EU5 BMT 6-speed manual	2,800	1550 / 1550	2500 / 750	5,200	1,885	915	1,917	883	1,946	854
	2.0TDI 140PS EU5 BMT 7-speed DSG	2,800	1550 / 1550	2500 / 750	5,300	1,909	891	1,941	859	1,970	830
	2.0BitDI 180PS EU5 BMT 6-speed manual	2,800	1550 / 1550	2500 / 750	5,200	-	-	-	-	1,970	830
	2.0BitDI 180PS EU5 BMT 7-speed DSG	2,800	1550 / 1550	2500 / 750	5,300	-	-	-	-	1,993	807
T30	2.0TDI 84PS EU5 BMT 5-speed manual	3,000	1500 / 1625	2200 / 750	4,800	1,855	1,145	-	-	-	-
	2.0TDI 102PS EU5 BMT 5-speed manual	3,000	1500 / 1625	2200 / 750	4,900	1,855	1,145	1,887	1,113	1,916	1,084
	2.0TDI 102PS EU6 BMT 5-speed manual	3,000	1500 / 1625	2200 / 750	4,900	1,882	1,118	1,914	1,086	1,942	1,058
	2.0TDI 140PS EU5 BMT 6-speed manual	3,000	1550 / 1625	2500 / 750	5,200	1,885	1,115	1,917	1,083	1,946	1,054
	2.0TDI 140PS EU5 BMT 7-speed DSG	3,000	1550 / 1625	2500 / 750	5,300	1,909	1,091	1,941	1,059	1,970	1,030
	2.0BitDI 180PS EU5 BMT 6-speed manual	3,000	1550 / 1625	2500 / 750	5,200	-	-	-	-	1,970	1,030
	2.0BitDI 180PS EU5 BMT 7-speed DSG	3,000	1550 / 1625	2500 / 750	5,300	-	-	-	-	1,993	1,007
T32	2.0TDI 102PS EU5 BMT 5-speed manual	3,200	1650 / 1720	2500 / 750	4,900	1,869	1,331	1,901	1,299	1,937	1,263
	2.0TDI 102PS EU6 BMT 5-speed manual	3,200	1650 / 1720	2200 / 750	4,900	1,896	1,304	1,928	1,272	1,955	1,245
	2.0TDI 140PS EU5 BMT 6-speed manual	3,200	1650 / 1720	2500 / 750	5,200	1,899	1,301	1,931	1,269	1,967	1,233
	2.0TDI 140PS EU5 BMT 7-speed DSG	3,200	1650 / 1720	2500 / 750	5,300	1,923	1,277	1,955	1,245	1,991	1,209
	2.0TDI 140PS EU5 4MOTION BMT 6-speed manual	3,200	1710 / 1720	2500 / 750	5,300	2,021	1,179	2,053	1,147	2,089	1,111
	2.0BitDI 180PS EU5 BMT 6-speed manual	3,200	1650 / 1720	2500 / 750	5,200	-	-	-	-	2,004	1,196
	2.0BitDI 180PS EU5 BMT 7-speed DSG	3,200	1650 / 1720	2500 / 750	5,300	-	-	-	-	2,027	1,173
	2.0BitDI 180PS EU5 4MOTION BMT 6-speed manual	3,200	1710 / 1720	2500 / 750	5,300	-	-	-	-	2,113	1,087
	2.0BitDI 180PS EU5 4MOTION BMT 7-speed DSG	3,200	1710 / 1720	2500 / 750	5,300	-	-	-	-	2,137	1,063

Long wheelbase.											
						Startline		Trendline		Highline	
T28	2.0TDI 84PS EU5 BMT 5-speed manual	2,800	1525 / 1550	2200 / 750	4,800	1,912	888	-	-	-	-
	2.0TDI 102PS EU5 BMT 5-speed manual	2,800	1525 / 1550	2200 / 750	4,900	1,912	888	1,944	856	1,972	828
	2.0TDI 102PS EU6 BMT 5-speed manual	2,800	1525 / 1550	2500 / 750	4,900	1,939	861	1,970	830	1,999	801
	2.0TDI 140PS EU5 BMT 6-speed manual	2,800	1575 / 1550	2500 / 750	5,200	1,942	858	1,974	826	2,002	798
	2.0TDI 140PS EU5 BMT 7-speed DSG	2,800	1575 / 1550	2500 / 750	5,300	1,966	834	1,998	802	2,026	774
	2.0BitDI 180PS EU5 BMT 6-speed manual	2,800	1550 / 1550	2500 / 750	5,200	-	-	-	-	2,027	773
	2.0BitDI 180PS EU5 BMT 7-speed DSG	2,800	1500 / 1550	2200 / 750	5,300	-	-	-	-	2,050	750
T30	2.0TDI 84PS EU5 BMT 5-speed manual	3,000	1525 / 1625	2200 / 750	4,800	1,912	1,088	-	-	-	-
	2.0TDI 102PS EU5 BMT 5-speed manual	3,000	1525 / 1625	2200 / 750	4,900	1,912	1,088	1,944	1,056	1,972	1,028
	2.0TDI 102PS EU6 BMT 5-speed manual	3,000	1525 / 1625	2500 / 750	4,900	1,939	1,061	1,970	1,030	1,999	1,001
	2.0TDI 140PS EU5 BMT 6-speed manual	3,000	1575 / 1625	2500 / 750	5,200	1,942	1,058	1,974	1,026	2,002	998
	2.0TDI 140PS EU5 BMT 7-speed DSG	3,000	1575 / 1625	2500 / 750	5,300	1,966	1,034	1,998	1,002	2,026	974
	2.0BitDI 180PS EU5 BMT 6-speed manual	3,000	1575 / 1625	2500 / 750	5,200	-	-	-	-	2,027	973
	2.0BitDI 180PS EU5 BMT 7-speed DSG	3,000	1575 / 1625	2500 / 750	5,300	-	-	-	-	2,050	950
T32	2.0TDI 102PS EU5 BMT 5-speed manual	3,200	1600 / 1720	2200 / 750	4,900	1,926	1,274	1,958	1,242	1,993	1,207
	2.0TDI 102PS EU6 BMT 5-speed manual	3,200	1600 / 1720	2500 / 750	4,900	1,953	1,247	1,984	1,216	2,011	1,189
	2.0TDI 140PS EU5 BMT 6-speed manual	3,200	1650 / 1720	2500 / 750	5,200	1,956	1,244	1,988	1,212	2,023	1,177
	2.0TDI 140PS EU5 BMT 7-speed DSG	3,200	1650 / 1720	2500 / 750	5,300	1,980	1,220	2,012	1,188	2,047	1,153
	2.0TDI 140PS EU5 4MOTION BMT 6-speed manual	3,200	1710 / 1720	2500 / 750	5,300	2,078	1,122	2,110	1,090	2,145	1,055
	2.0BitDI 180PS EU5 BMT 6-speed manual	3,200	1650 / 1720	2500 / 750	5,200	-	-	-	-	2,060	1,140
	2.0BitDI 180PS EU5 BMT 7-speed DSG	3,200	1650 / 1720	2500 / 750	5,300	-	-	-	-	2,083	1,117
	2.0BitDI 180PS EU5 4MOTION BMT 6-speed manual	3,200	1710 / 1720	2500 / 750	5,300	-	-	-	-	2,169	1,031
	2.0BitDI 180PS EU5 4MOTION BMT 7-speed DSG	3,200	1710 / 1720	2500 / 750	5,300	-	-	-	-	2,193	1,007

Kombi weights.

Model	Engine	Gross vehicle weight kg	Axle load limit front/rear kg	Trailer weight braked 12%/ unbraked kg	Gross train weight kg	Unladen weight ¹ kg	Payload ² kg	Unladen weight ¹ kg	Payload ² kg	Unladen weight ¹ kg	Payload ² kg
Short wheelbase.											
						Startline		Trendline		Highline	
T30	2.0TDI 84PS EU5 BMT 5-speed manual	3,000	1500 / 1625	2200 / 750	4,800	1,952	1,048	-	-	-	-
	2.0TDI 102PS EU5 BMT 5-speed manual	3,000	1500 / 1625	2200 / 750	4,900	1,976	1,024	1,976	1,024	1,993	1,007
	2.0TDI 102PS EU6 BMT 5-speed manual	3,000	1500 / 1625	2200 / 750	4,900	1,978	1,022	1,991	1,009	2,019	981
	2.0TDI 140PS EU5 BMT 6-speed manual	3,000	1550 / 1625	2500 / 750	5,200	1,982	1,018	1,995	1,005	2,023	977
	2.0TDI 140PS EU5 BMT 7-speed DSG	3,000	1550 / 1625	2500 / 750	5,200	2,006	994	2,019	981	2,047	953
	2.0TDI 140PS EU5 4MOTION BMT 6-speed manual	3,080	1550 / 1625	2500 / 750	5,300	2,104	976	2,117	963	2,145	935
	2.0BitDI 180PS EU5 BMT 6-speed manual	3,000	1550 / 1625	2500 / 750	5,200	-	-	-	-	2,047	953
	2.0BitDI 180PS EU5 BMT 7-speed DSG	3,000	1550 / 1625	2500 / 750	5,300	-	-	-	-	2,070	930
	2.0BitDI 180PS EU5 4MOTION BMT 6-speed manual	3,080	1550 / 1625	2500 / 750	5,300	-	-	-	-	2,170	910
	2.0BitDI 180PS EU5 4MOTION BMT 7-speed DSG	3,000	1550 / 1625	2500 / 750	5,300	-	-	-	-	2,194	806
T32	2.0TDI 102PS EU5 BMT 5-speed manual	3,200	1650 / 1720	2500 / 750	4,900	1,976	1,224	1,979	1,221	2,013	1,187
	2.0TDI 102PS EU6 BMT 5-speed manual	3,200	1650 / 1720	2200 / 750	4,900	1,992	1,208	2,005	1,195	2,046	1,154
	2.0TDI 140PS EU5 BMT 6-speed manual	3,200	1650 / 1720	2500 / 750	5,200	1,996	1,204	2,009	1,191	2,043	1,157
	2.0TDI 140PS EU5 BMT 7-speed DSG	3,200	1650 / 1720	2500 / 750	5,300	2,020	1,180	2,033	1,167	2,067	1,133
	2.0TDI 140PS EU5 4MOTION BMT 6-speed manual	3,200	1710 / 1720	2500 / 750	5,300	2,118	1,082	2,131	1,069	2,165	1,035
	2.0BitDI 180PS EU5 BMT 6-speed manual	3,200	1650 / 1720	2500 / 750	5,200	-	-	-	-	2,080	1,120
	2.0BitDI 180PS EU5 BMT 7-speed DSG	3,200	1650 / 1720	2500 / 750	5,300	-	-	-	-	2,103	1,097
	2.0BitDI 180PS EU5 4MOTION BMT 6-speed manual	3,200	1710 / 1720	2500 / 750	5,300	-	-	-	-	2,189	1,011
	2.0BitDI 180PS EU5 4MOTION BMT 7-speed DSG	3,200	1710 / 1720	2500 / 750	5,300	-	-	-	-	2,213	987

Long wheelbase.											
						Startline		Trendline		Highline	
T32	2.0TDI 102PS EU5 BMT 5-speed manual	3,200	1600 / 1720	2200 / 750	4,900	2,029	1,171	2,042	1,158	2,077	1,123
	2.0TDI 102PS EU6 BMT 5-speed manual	3,200	1600 / 1720	2500 / 750	4,900	2,055	1,145	2,068	1,132	2,109	1,091
	2.0TDI 140PS EU5 BMT 6-speed manual	3,200	1650 / 1720	2500 / 750	5,200	2,059	1,141	2,072	1,128	2,107	1,093
	2.0TDI 140PS EU5 BMT 7-speed DSG	3,200	1650 / 1720	2500 / 750	5,300	2,083	1,117	2,096	1,104	2,131	1,069
	2.0TDI 140PS EU5 4MOTION BMT 6-speed manual	3,200	1710 / 1720	2500 / 750	5,300	2,181	1,019	2,194	1,006	2,229	971
	2.0BitDI 180PS EU5 BMT 6-speed manual	3,200	1650 / 1720	2500 / 750	5,200	-	-	-	-	2,144	1,056
	2.0BitDI 180PS EU5 BMT 7-speed DSG	3,200	1650 / 1720	2500 / 750	5,300	-	-	-	-	2,167	1,033
	2.0BitDI 180PS EU5 4MOTION BMT 6-speed manual	3,200	1710 / 1720	2500 / 750	5,300	-	-	-	-	2,253	947
	2.0BitDI 180PS EU5 4MOTION BMT 7-speed DSG	3,200	1710 / 1720	2500 / 750	5,300	-	-	-	-	2,277	923

Service and warranties.

Finance and insurance.

When it comes to paying for your van, we've got options including Contract Hire and Finance Lease, or Hire Purchase. We can also offer you competitive insurance.

A choice of packages.

Whether you prefer to lease your vehicles, with none of the concerns of ownership and the freedom to change models easily, or purchase outright to own the vehicle that's perfect for your business, we're here to help you make the best decision.

You can go flexible, by choosing a payment plan that suits your finances, with options to reduce your monthly costs and your repayment period. Or choose a fixed monthly price that allows you to budget confidently for the longer term.

You can even include your road tax and servicing costs to arrive at one simple, all-inclusive payment. For more information, pick up a finance brochure, or ask at your Van Centre.

Volkswagen insurance.

Volkswagen Commercial Vehicles Insurance provides cost-effective and comprehensive motor insurance, as well as gap insurance, which helps replace your vehicle and protect you from any financial shortfall if it's written off.

Insurance benefits include:

- Complimentary five-day insurance cover to allow you to drive your vehicle away.
- All repairs performed by approved repairers.
- Volkswagen Genuine Parts® used on all repairs.
- Courtesy vehicle provided during repair following an accident.
- Cover for breakage and damage to glass.
- Tools-in-transit cover (up to £1,000).
- In-vehicle personal belongings cover (up to £500).
- Vehicle recovery.
- 60-day European Union cover.
- Legal expenses cover (up to £100,000).

For more information about motor and gap insurance products, ask at your Van Centre, call **0800 316 7896**, or visit insurewithvwcv.co.uk.

Servicing and support.

We're here to keep your business moving, with our range of three award-winning¹ servicing and maintenance options, as well as free Roadside Assistance.

Pay monthly.

This option is available for vehicles that are less than 12 months old and have covered less than 10,000 miles. It makes budgeting easier by splitting the cost of servicing into fixed monthly payments – whether you want Service only, Service and Maintenance or Service, Maintenance and Tyres.

Pay upfront.²

If you can pay for more than one service upfront, we'll help by reducing your costs. Buy two upfront and you'll receive one interim and one full service at a discounted rate. Buy four and you'll receive two interim and two full services, with your next MOT also included.

Pay on demand.

If you're looking for freedom and flexibility with your servicing, it's good to know we're ready when you are. So with our third option, you can choose to pay for your services as and when you need them, with our National Service Pricing. Ask your Van Centre for an up-to-date pricing guide.

Roadside Assistance.

We understand the need to keep you mobile. That's why all new vans come with three-year, unlimited mileage roadside cover. Should the unexpected happen, one call gets you straight through to a team trained to help you through any breakdown or accident. Supporting you every day will be a team of vehicle technicians, fully-trained by Volkswagen and carrying the latest diagnostic equipment, specialist tools and parts.

Assistance benefits include:

- Assistance at home, by the roadside or place of work.
- Recovery to your preferred location.
- Onward travel, for you and your cargo.
- Cover 24 hours a day, 365 days a year.
- Free cover for three years (on new vehicles).
- Unlimited mileage.
- European cover.
- Option to extend cover beyond three years.

Warranties.

You can count on us long after you purchase your Transporter, thanks to its comprehensive three-year, 100,000 mile warranty. You choose Volkswagen because your business depends on it, year in, year out.

While your Transporter is under warranty, we'll fix any defect in manufacture or workmanship free of charge, even if you purchase and service the vehicle at different Van Centres.

Extended warranty.

You can also extend your warranty beyond the three-year, 100,000 mile period, choosing either Comprehensive or Major Component cover, as a one-off or monthly payment. For full details of cover levels, along with terms and conditions, please visit volkswagencvwarranty.co.uk where you'll also be able to obtain a quote and purchase an extended warranty.

Paint and body warranty.

Your Transporter's exterior paintwork is covered against manufacturing defects for a period of three years, while its body sections and panels are covered against rusting through from the inside for 12 years. Some exclusions apply and the vehicle must be cared for using the guidance in your owner's manual.

Please note: Print processes do not allow exact reproduction of the paint and upholstery colours. Some of the vehicles shown are European specification and may be fitted with optional equipment or accessories that are available at extra cost, or do not reflect current specification. All data and specifications are in accordance with information available at the time of going to print and are subject to change without notice. Vehicles not currently in UK stock and customer order vehicles may take a number of weeks for delivery. Certain combinations of vehicle specifications and factory-fitted extras are not compatible and therefore all orders received are subject to confirmation. Models, factory fitted-options and paint and upholstery options are subject to availability. Please check details and availability with an authorised Volkswagen Van Centre at the time of ordering.

Volkswagen Commercial Vehicle Finance is a trading name of Volkswagen Financial Services (UK) Limited, Brunswick Court, Yeomans Drive, Blakelands, Milton Keynes MK14 5LR. Registered in England number: 2835230. An offer of finance depends on certain conditions. Subject to status, indemnities may be required. Available to over 18s in the UK only. Volkswagen Commercial Vehicles Insurance is a trading name of Volkswagen Financial Services (UK) Limited (VWFS UK). Registered in England and Wales number: 2835230. Registered Office: Brunswick Court, Yeomans Drive, Blakelands, Milton Keynes MK14 5LR. Financial and consumer credit services are provided by VWFS UK. Volkswagen Financial Services (UK) Limited is authorised and regulated by the Financial Conduct Authority, registration number: 311988. Volkswagen Commercial Vehicles Insurance from Volkswagen Financial Services is sold and administered by Ageas Retail Limited, registered in England and Wales number: 1324965. Registered office: Ageas House, Hampshire Corporate Park, Templars Way, Eastleigh, Hampshire SO53 3YA. Ageas Retail Limited is authorised and regulated by the Financial Conduct Authority (FCA), registration number: 312468. Volkswagen Financial Services (UK) and Ageas Retail Limited are not part of the same corporate group.

Add Ons
Accessories to help keep your vehicle 100% Volkswagen.

Add extra style, protection and practicality to your van, while still keeping it 100% Volkswagen.

Add more with Add Ons...

Accessories allow you to go beyond options and truly customise your van. You might want extra capacity with roof attachments or a tow bar, add cab technology or even convert a work van into a weekend leisure vehicle. Whatever you need, there's something in our Add Ons range for you.

Keep it 100% Volkswagen.

There are big advantages to purchasing approved accessories from us. Add Ons have all been designed with your Volkswagen in mind, so they're a perfect match for fit and style. They're also rugged, reliable and long-lasting.

Keep your Add Ons covered.

Most Add Ons include a two-year warranty, but the great news is that if you order and fit them when you purchase a new van, we may be able to extend that to three years to match your vehicle's warranty. Ask your Van Centre for more details.

¹ Business Vans Awards 2014: Best Service Package for Van Owners.

² Class 4 MOT only. This option is available to all new and used vehicles up to four years old or with less than 80,000 miles on the clock. Services must be used consecutively prior to vehicle reaching eight years old.

VWV16TRANS

This brochure supersedes all previous publications.

Issue: September 2015

www.volkswagen-vans.co.uk