

The C-Class Saloon



Mercedes-Benz



Never stop improving.

The sense of forward momentum in the new C-Class Saloon is plain to see: the modified front end simply exudes dynamism and contemporary appeal. Depending on the precise specification, it features redesigned bumpers, gleaming chrome trim and stunning new LED headlamps.



The image shows the front interior of a Mercedes-Benz C-Class Saloon. The steering wheel is black with a silver Mercedes-Benz logo in the center and features touch-sensitive controls on the spokes. The instrument cluster is fully digital, displaying speed, temperature, and other vehicle information. The center console has a large infotainment screen showing a music interface, three circular air vents, and a gear selector. The interior is finished with black leather and brown perforated leather seats.

When it all feels perfect,
there can only be one objective:
to make it even better.

Perfect training conditions await you in the new C-Class Saloon: the new steering wheel with Touch Control buttons along with, depending on the precise specification, fully digital instruments and larger displays including a new-generation multimedia system, are state-of-the-art features that make operating the car a highly individual affair.

Mercedes-Benz Intelligent Drive.

Be it during the rush hour, on long night-time journeys or on unfamiliar routes. Your new Mercedes-Benz C-Class Saloon provides tangible relief in stressful situations. It's all down to a concept that makes every journey in a Mercedes-Benz such a safe and exceptional experience: Mercedes-Benz Intelligent Drive.





Digital cockpit.

Smartphone Integration connects the mobile phone with the media system via Apple CarPlay™ or Android Auto, thus providing convenient access to the most important applications of your smartphone. It also allows quick and easy use of apps from third-party service providers such as Spotify®.

YOUR GATEWAY TO THE DIGITAL WORLD OF MERCEDES-BENZ

The fully digital instrument display with the display styles “Classic”, “Progressive” and “Sporty” enables you to decide which information is important to you and how you wish to see it displayed. The 31.2 cm (12.3-inch) display delivers a pin-sharp image which is very easy to read in all light conditions.

The high-resolution media display in a 16:9 format with 10.25-inch screen diagonal adds a particularly high-quality touch to the interior of your vehicle. Thanks to the higher resolution of 1920 x 720 pixels you can enjoy brilliant image quality with crisp presentation of all infotainment content.



Blind Spot Assist.

Blind Spot Assist reduces the risk of an accident, in particular during lane changes but also when at a standstill. It monitors the vehicle's blind spot and is able to provide you with a visual and audible warning of detected dangers. It operates not only while driving, but also for up to three minutes after switching off the ignition.



Burmester® surround sound system.

Surround sound and superb tone in all seats: the Burmester® surround sound system offers music lovers an experience that is absolutely unbeatable in this segment. The overall sound pattern can be individually set to suit your own personal preference and the type of music being played – allowing you to enjoy exceptional quality at almost concert-hall level.



Ambient lighting.

Set the mood in the interior to suit your personal preference or current frame of mind. With a total of 64 colours to play with, the ambient lighting system offers almost unlimited opportunities to set the lighting mood, with the right colour to suit any situation.



Panoramic sliding roof.

Whether open or closed: with the panoramic sliding sunroof you can experience an amazing sense of freedom and enjoy a light and airy atmosphere in the interior. Seen from the outside, too, the generously proportioned sliding sunroof has a unique effect, giving the exterior an air of lightness and exclusivity.

FURTHER HIGHLIGHTS

It's possible to switch between a sporty and a comfortable configuration at the simple touch of a button, courtesy of the DYNAMIC SELECT switch in conjunction with one or other of the two available suspensions, DYNAMIC BODY CONTROL and AIR BODY CONTROL.

DYNAMIC BODY CONTROL.

One suspension – three possible set-ups: with DYNAMIC BODY CONTROL, you can choose between maximum agility and high damping comfort. To match the route and your personal driving style. The low suspension level and the Sports Direct-Steer system provide you with the ideal conditions for a particularly dynamic driving style. The DYNAMIC BODY CONTROL suspension is equipped with continuously adjustable damping for both the front and rear axle. The stepless system interacts with the engine, transmission and steering characteristics to control the damping individually for each wheel – matched to the driving situation, vehicle speed and road surface. This variable configuration allows you to benefit from superb travelling comfort and outstanding driving dynamics.

4MATIC all-wheel drive.

In city traffic, on country roads or on the motorway: with the permanent all-wheel drive system from Mercedes-Benz you will always feel safe on the road. The system improves traction when pulling away or accelerating, especially on a poor road surface. This is made possible by the perfect interplay between the 4MATIC system

and the electronic braking, control and traction systems ABS, ESP® and 4ETS. The all-wheel drive system is constantly active and does not require any reaction time before intervening. Particularly on wet, snowy or icy roads, the improvement in driving and tracking stability is quite noticeable.



The AVANTGARDE equipment line.

With the AVANTGARDE exterior you can emphasise the individuality of your vehicle – and demonstrate the appeal of contemporary sportiness. The outcome of the interplay between the various design elements is an extraordinarily expressive vehicle. The lowered suspension offers the ideal balance between dynamism, comfort and safety.

The AVANTGARDE interior allows you to show what matters to you: stylish sportiness, characterful individuality and top-class quality.



The AMG Line.

The expressive styling of the AMG Line lends the exterior of the C-Class a sporty, exclusive touch. As such you can make a clear statement for powerful design. On top of this, the technical features give you palpably more fun at the wheel, since the agile configuration of the suspension with Sports Direct-Steer makes the handling noticeably dynamic. The AMG Line interior adds to the vehicle's sportiness, both visibly and tangibly. With it, you make a clear statement and show immediately what matters to you: an ambience that is dynamic and exclusive in every single detail.



No compromises.

Every Mercedes-AMG is a masterpiece in its own right, with an unmistakable character. What unites our performance vehicles and sports cars is their irrepressible sporting spirit. Their passion for top performance. It is generated at the point where engineering skill meets a very special attitude: the spirit of AMG. We believe that you have to keep on challenging limits in order to achieve new goals. We accept nothing as a given. Because limits are imposed by people, and it's also people who can overcome them. It's this attitude that enables us to achieve outstanding performance for the race track – and for the road.

Welcome to the world of AMG.

www.mercedes-amg.com



AMG
DRIVING PERFORMANCE

Technical data.

| |
|--|
| Displacement (cc) |
| Rated output ¹ (kW [hp] at rpm) |
| Transmission |
| Acceleration 0-100 km/h (sec.) |
| Top speed (km/h) |
| Fuel consumption ⁴ (l/100 km) |
| Urban |
| Extra-urban |
| Combined |
| Combined CO ₂ emissions ⁴ (g/km) |

Petrol engines

| C 200 | C 300 | AMG C 43 4MATIC |
|-------------------------|-------------------------|-----------------|
| 1.497 | 1.991 | 2.996 (V6) |
| 135 [184]/5.800 - 6.100 | 190 [258]/5.800 - 6.100 | 287 [390]/6.100 |
| automatic | automatic | automatic |
| 7.7 | 5.9 | 4.7 |
| 239 | 250 | 250 |
| 8.2 - 7.9 | 9.3 - 8.9 | 12.6 - 12.2 |
| 5.2 - 4.9 | 5.5 - 5.1 | 7.5 - 7.2 |
| 6.3 - 6.0 | 6.9 - 6.5 | 9.3 - 9.1 |
| 144 - 136 | 158 - 148 | 213 - 208 |

The best for the engine:
Mercedes-Benz genuine engine oils.

¹Information about the rated output according to Regulation (EC) No. 715/2007 in the currently applicable version. ²Available temporarily. ³Electronically limited. ⁴The stated figures were determined according to the prescribed measurement method. They constitute the "NEDC CO₂ figures" pursuant to Art. 2 No. 1 Implementing Regulation (EU) 2017/1153. Fuel consumption figures have been calculated on this basis. More information about the official fuel consumption and the official specific CO₂ emissions of new passenger cars is available in the publication entitled "Leitfaden über den Kraftstoffverbrauch, die CO₂-Emissionen und den Stromverbrauch neuer Personenkraftwagen" ["Guidelines concerning the fuel consumption, CO₂ emissions and electricity consumption of new passenger cars"], available free of charge from all retailers and from Deutsche Automobil Treuhand GmbH (www.dat.de). The figures are not based on an individual vehicle and do not constitute part of the product offer; they are provided solely for purposes of comparison between different vehicle models. The figures will vary according to the optional equipment selected. For more technical data, please visit www.mercedes-benz.com.my

Dimensions.

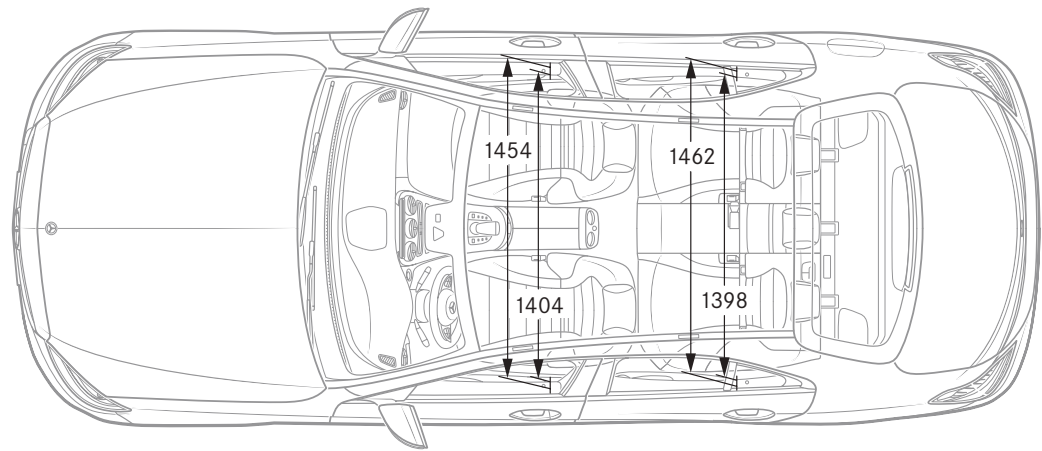
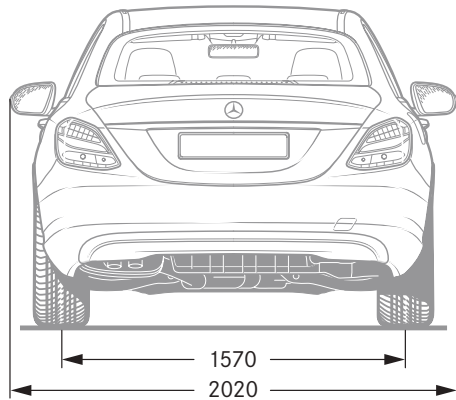
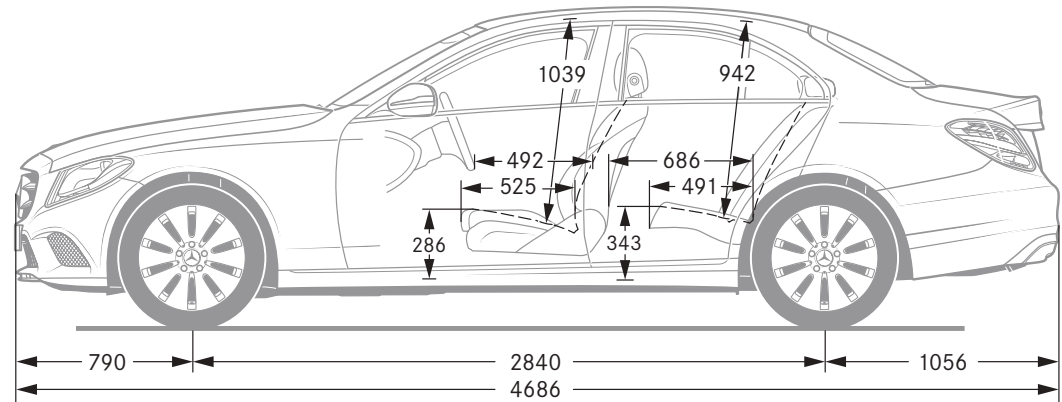
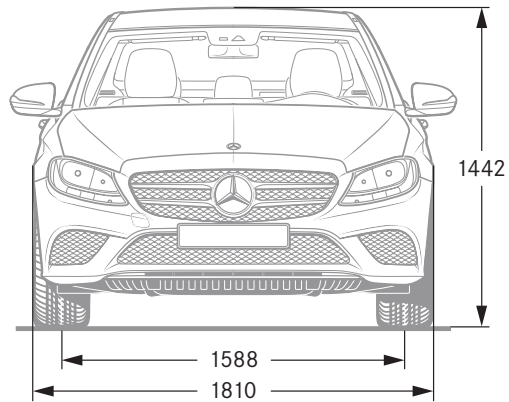

All figures in millimetres. The illustrated dimensions are mean values. They are valid for vehicles in basic specification and in unladen condition.